

# TECHNICAL MANUAL



**UWT 6008** Multichannels Weight transmitter/indicator

Software version P32001



# TABLE OF CONTENTS

PRECAUTIONS .....	Page 2
INTRODUCTION .....	Page 3
TECHNICAL FEATURES .....	Page 5
INSTALLATION .....	Page 6
FRONT PANEL OF THE INSTRUMENT .....	Page 14
USING THE KEYBOARD .....	Page 15
INFO DISPLAY .....	Page 18
OPERATING FUNCTIONS .....	Page 19
SETTING.....	Page 23
CONFIGURATION PARAMETERS.....	Page 27
CALIBRATION.....	Page 27
ANALOG PARAMETERS .....	Page 34
SERIAL PARAMETERS.....	Page 36
INPUT/OUTPUT PARAMETERS.....	Page 46
WEIGHING PARAMETERS .....	Page 49
FILTER - SETTING FILTER PARAMETERS .....	Page 51
SETTING FUNCTIONAL FEATURES .....	Page 53
SET DATE AND TIME.....	Page 56
SERIAL COMMUNICATION PROTOCOLS .....	Page 59
FIELDBUS PROTOCOL .....	Page 71
TROUBLESHOOTING .....	Page 76

## PRECAUTIONS

READ this manual BEFORE operating or servicing the instrument.

FOLLOW these instructions carefully.

KEEP this manual for future use.



### WARNING

The purpose of this manual is to provide the operator with explanatory text and figures, the requirements and basic criteria for the installation and correct use of the instrument.

The installation, maintenance and repair should only be carried out by specialised personnel who have read and understood this manual. "Specialised personnel" means personnel who, because of their training and professional experience have been expressly authorised by the plant Safety Officer to carry out the installation.

Power the instrument with a voltage whose value is within the limits specified in the specifications.

The user is responsible for ensuring that the installation complies with the provisions in force.

Any attempt to dismantle or modify the instrument which is not expressly authorised will invalidate the warranty and will relieve Pavone Sistemi from all liability.

Installation and maintenance of this instrument must be entrusted to qualified personnel only.

Be careful when performing inspections, tests and adjustments with the instrument on.

Perform the electrical connections with the instrument unplugged from the mains

Failure to observe these precautions may be dangerous.

DO NOT allow untrained personnel to work, clean, inspect, repair or alter this instrument.

# INTRODUCTION

UWT 6008 is a weight transmitter, result of the most recent and advanced technology for weighing and measuring systems of load cells. The instrument allows to display separately up to a maximum of 8 channels.

The instrument converts the mV signal of the load cells into a high resolution digital signal (24 bits) for each individual cell, the sum of the individual channels will therefore give more precise information on the weight value acquired.

The transmitter can be integrated as a slave in different types of network, through various serial communication protocols or Fieldbus.

The advantages of transmitting the individual weight values of the load cells are as follows:

1. Independent display of the output in mV / V and of the weight value of each individual cell.
2. Monitoring of all load cells and alarm generation for excessive cell signal drifts, missing connections, failure of one of the cells, unbalanced weight distribution.
3. The emulative control allows the continuity of work of the weighing system even in case of failure on a single load cell, until repair or replacement.
4. The equalization function automatically compensates for the differences between the weight values detected by the load cells during the start of the weighing system.
5. A particular algorithm allows to equalize the angles of the scale with only 1 passage of the sample weight (instead of the numerous steps required by the traditional regulation).

Available versions:

- **UWT 6008:** weight transmitter with RS232 serial output, USB, RS485 and peak function. Supported protocols are Modbus RTU, continuous, slave and on demand. Two programmable set points, 2 inputs and Peak function.
- **UWT 6008/A:** version with the analog output.
- **UWT 6008/PROFINET:** weight transmitter with RS232 serial output, USB and PROFINET.
- **UWT 6008/ETHERNET IP:** weight transmitter with serial output RS232 and ETHERNET IP.
- **UWT 6008/ETHERCAT:** weight transmitter with serial output RS232 and ETHERCAT.
- **UWT 6008/ETHERNET :** weight transmitter with serial output RS232 and ETHERNET.
- **UWT 6008/PROFIBUS:** weight transmitter with serial output RS232 and PROFIBUS.

## IDENTIFICATION PLATE OF THE INSTRUMENT

Always cite this data when requesting information or instructions concerning the instrument, as well as the program number and version that are shown on the cover of the manual and on the display when the instrument is switched on.

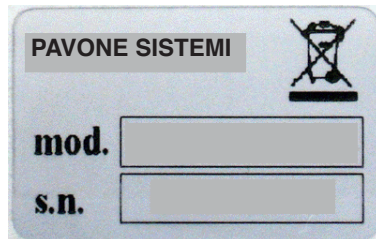

### WARNINGS

The following procedures must be entrusted to qualified personnel.  
All connections must be made with the instrument turned off.

## TECHNICAL FEATURES

Power supply	12 ÷ 24 Vdc ± 15 %
Max. absorption	4 W
Isolation	Class II
Installation category	Cat. II
Operating temperature	-10°C ÷ +50°C (max humidity 85% without condensate)
Storage temperature	-20°C ÷ +70°C
Weight display	Graphic LCD 128 x 64 pixels
Keyboard	4 membrane keys
Overall dimensions	100 x 75 x 110 mm (L x H x P)
Assembly	On support for DIN profile or OMEGA bar
Container material	Self-extinguishing Noryl (UL 94 V1)
Connections	Removable terminal boards pitch 3.81.
Load cells power supply	5 Vdc (max 16 cells x 350 Ω in parallel) short-circuit protected
Input sensitivity	0.02 µV min.
Linearity	< 0.01% of full scale
Temperature drift	< 0.001% of full scale / C°
Internal resolution	24 bit
Displayed weight resolution	Up to 999,999 divisions on useful capacity
Measuring range	From -3,9 mV/V to +3,9 mV/V
Weight acquisition frequency	12.5 Hz - 300 Hz
Digital filter	Selectable 0,25 ÷ 25 Hz (up to 250 Hz in manual)
Weight decimal number	from 0 to 4 decimal digits
Zero calibration and full scale	Automatic (theoretical) or executable from the keyboard.
Logic input	2 optoinsulated (free contact) max 24Vdc / 100 mA ea.
Logic output	4 Relay max 48 Vdc / ac, 2 A (2 Relays when present Analog Output)
Serial port (n° 2)	RS232C and RS485
Maximum cable length	15m (RS232C) and 1000m (RS485)
Serial protocols	ASCII, Modbus RTU
Baud rate	1200, 2400, 4800, 9600, 19200, 38400, 57600, 115200 selectable
USB port device:	complies with USB 2.0; up to 12 Mbps speed
Analogue output (optional)	optoinsulated 16 Bit Voltage: 0÷5/10 V (R min 10 K Ohm), Current: 0/4÷20 mA (R max 300 Ohm)
Analogue output calibration	From keyboard
Linearity	< 0,02% FS
Thermal drift	0,001% FS / °C
Microcontroller:	ARM Cortex M0+ to 32 bit, 256KB Flash reprogrammable on-board by USB.
Data storage	64 Kbytes expandable up to 1024 Kbytes
Fieldbus (alternative to RS485)	PROFINET, ETHERNET IP, ETHERCAT, ETHERNET, PROFIBUS
Regulatory Compliance	EN61000-6-2, EN61000-6-3 , EN61010-1

# INSTALLATION

## GENERAL DATA

The UWT 6008 comprises a motherboard, to which various options can be added; the motherboard is housed in a plastic 35mm DIN rail mount enclosure.



The UWT 6008 should not be immersed in water, subjected to jets of water, and cleaned or washed with solvents.

Do not expose to heat or direct sunlight.

Do not install the instrument near power equipment (motors, inverters, contactors, etc.) or anyhow equipment that does not comply with CE standards for electromagnetic compatibility.

The connection cable for the load cells must have a maximum length of 140mt/mm<sup>2</sup>.

The RS232 serial line must have a maximum length of 15 meters (standard EIA RS-232-C).

The recommendations given for connecting the individual devices must be adhered to.

## OVERALL DIMENSIONS

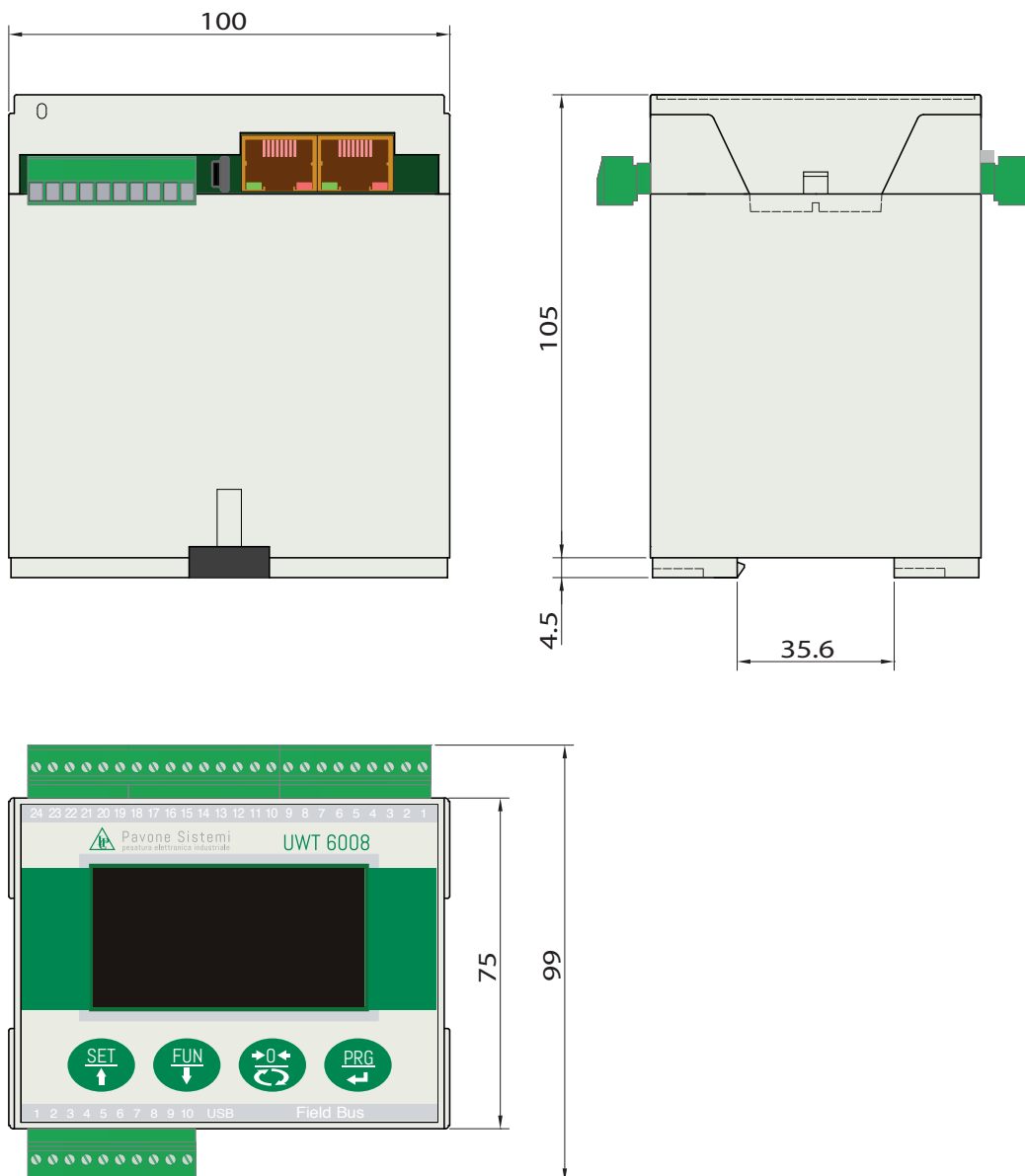



## ELECTRICAL INSTALLATION



UWT 6008 송신기는 전기 연결을 위해 3.81mm 간격의 탈착식 나사 단자대를 사용합니다. 로드셀 케이블은 전자기 간섭을 방지하기 위해 차폐되어야 하며 전원 케이블과 분리하여 설치해야 합니다.

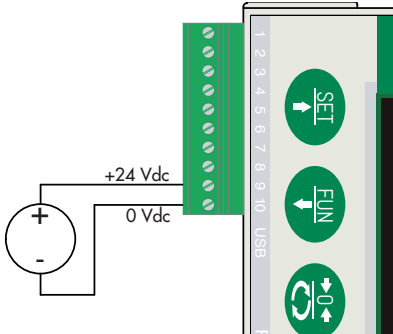

## POWER SUPPLY OF THE INSTRUMENT

이 기기는 9번 및 10번 단자를 통해 전원이 공급됩니다. 전원 케이블은 다른 케이블과 별도로 연결해야 합니다.

본 기기는 절연 등급 II(이중 절연)이며 접지 단자가 제공되지 않습니다.

Power supply voltage: 12÷24 Vcc ±15%, max 4W

## LOAD CELL(S) CONNECTIONS

셀(들)의 케이블은 다른 케이블과 섞이지 않고 별도로 배선해야 합니다

옵션 구성의 계측기는 8개의 채널을 갖추고 있으며, 최대 16개의 350옴 부하셀을 구동할 수 있습니다. 따라서 각 채널에 350옴 부하셀 2개를 병렬로 연결할 수 있습니다. 부하셀의 공급 전압은 5Vcc이며, 일시적인 단락 회로로부터 보호됩니다.

이 기기의 측정 범위는 최대 3.9mV/V의 감도를 가진 로드셀을 사용할 수 있도록 합니다.

Load cell connection table.

Upper terminal block			Lower terminal board		
1	LC 1	+EXC	25	LC 5	+EXC
2		+Signal	26		+Signal
3		-Signal	27		-Signal
4		-EXC / shield	28		-EXC / shield
5	LC 2	+EXC	29	LC 6	+EXC
6		+Signal	30		+Signal
7		-Signal	31		-Signal
8		-EXC / shield	32		-EXC / shield
9	+Sense		33	+Sense	
10	-Sense		34	-Sense	
11	LC 3	+EXC	35	LC 7	+EXC
12		+Signal	36		+Signal
13		-Signal	37		-Signal
14		-EXC / shield	38		-EXC / shield
15	LC 4	+EXC	39	LC 8	+EXC
16		+Signal	40		+Signal
17		-Signal	41		-Signal
18		-EXC / shield	42		-EXC / shield

감지 단자는 모든 로드셀에서 공통으로 사용됩니다. 4선식 로드셀의 경우, +EXC와 +Sense 단자 사이, 그리고 -EXC와 -Sense 단자 사이에 접퍼를 연결하십시오.

로드셀 케이블의 차폐선을 -EXC 단자에 연결하십시오

## LOGIC INPUTS

두 개의 논리 입력은 광 절연되어 있습니다.



로직 입력에 연결되는 케이블은 전원 케이블과 함께 배치해서는 안 됩니다.

연결 케이블의 길이를 최소화하십시오.

두 입력의 기능은 설정에서 선택할 수 있습니다.

두 기능은 그림에 표시된 대로 24Vdc 외부 전원을 해당 단자에 연결함으로써 활성화됩니다.

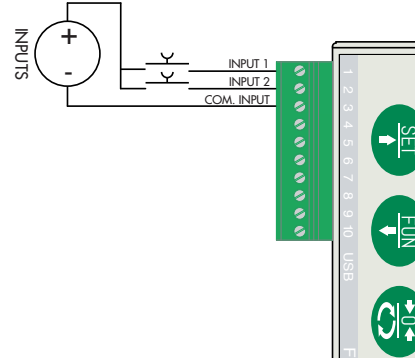

## LOGIC OUTPUTS

4개의 릴레이 출력은 상시 개방 접점을 갖습니다. **각 접점의 용량은 48Vac/cc, 최대 2A입니다**



출력 연결 케이블은 전원 케이블과 함께 채널형으로 연결할 필요가 없습니다. 연결 케이블은 가능한 한 짧아야 합니다.

장비가 설치된 환경은 일반적으로 강한 자기장과 주변 기계로 인한 전기적 교란에 노출될 수 있으므로, 전자 정밀 기기의 일반적인 신호에 영향을 미치지 않도록 일반적인 예방 조치를 취하는 것이 좋습니다. (원격 제어 스위치에 필터 설치, 24VDC 릴레이에 다이오드 사용 등)

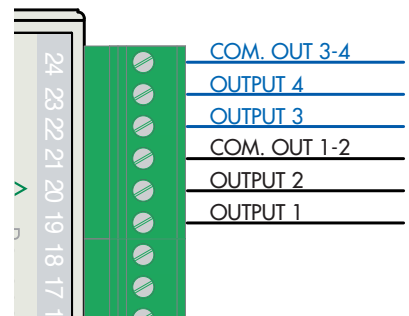

## SERIAL COMMUNICATION

### RS232:

RS232 직렬 포트는 일반적으로 PC, 프린터 및 중계기와의 연결에 사용됩니다.

직렬 연결을 하려면 적절한 차폐 케이블을 사용하고, 케이블 양쪽 끝 중 한쪽 끝에만 차폐선을 접지해야 합니다.



케이블은 전원 케이블과 함께 매설해서는 안 되며, 최대 길이는 15미터(EIA RS-232-C)입니다. 더 긴 케이블을 사용해야 하는 경우, 옵션 사양인 RS485 인터페이스를 사용해야 합니다.

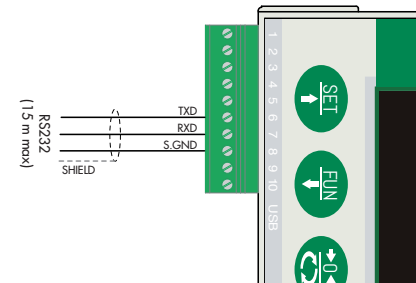

### RS485:

RS485 직렬 연결은 2선식이며, 차폐 트위스트 케이블을 사용하여 최대 32개의 계측기를 하나의 마스터 장치(PC, PLC 등)에 연결할 수 있습니다. 이때 케이블의 양쪽 끝 중 한쪽 끝은 차폐선을 접지에 연결해야 합니다



해당 케이블은 전력 케이블과 함께 덕트에 넣어서는 안 됩니다.

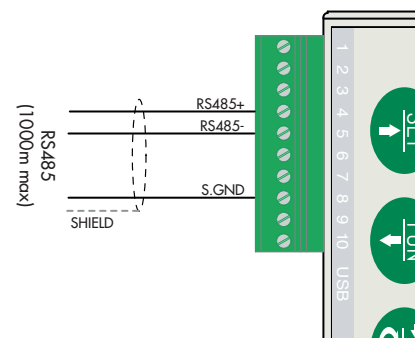

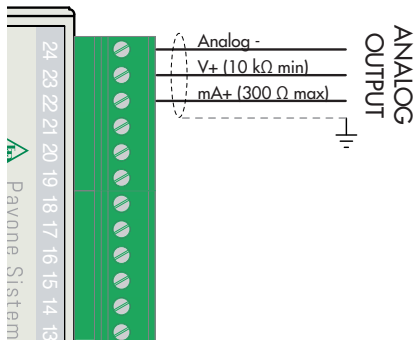

## ANALOG OUTPUT (OPTIONAL)

송신기는 전류 또는 전압 형태의 아날로그 출력을 제공합니다.

아날로그 출력 전압: 범위는 0~10V 또는 0~5V이며, 최소 부하 저항은 10kΩ입니다.

아날로그 출력 전류 범위: 0~20mA 또는 4~20mA. 최대 부하 저항은 300Ω입니다.



아날로그 전송은 전자기 간섭에 민감할 수 있으므로 케이블은 가능한 한 짧게 하고 자체 경로를 따라 설치하는 것이 좋습니다.

연결하려면 적절한 차폐 케이블을 사용하고, 케이블의 양쪽 끝 중 한쪽 끝에서 차폐선을 접지에 연결해야 합니다.

주의: 아날로그 출력을 작동 중인 장치에 연결하지 마십시오.

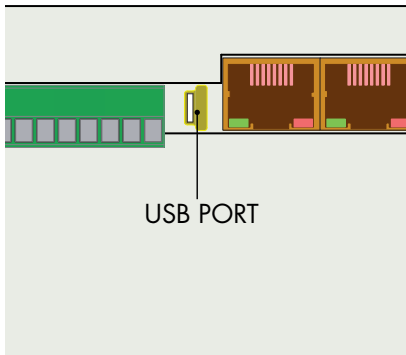

## USB 장치 (2.0 규격 준수, 최대 속도 12Mbps)

이 통신 포트를 사용하여 USB 포트를 통해 PC와 직접 연결할 수 있습니다. 연결에는 표준 USB 케이블을 사용하십시오.

USB 장치를 통해 기기를 연결하려면 사용 중인 운영 체제에 적합한 드라이버를 PC에 설치해야 합니다.

설치 시에는 구체적인 지침을 따르십시오.

## FIELD BUS CONNECTIONS

RS485 직렬 포트 대신 가장 일반적인 필드버스들을 사용할 수 있습니다. 주문 시 사용할 필드버스를 하나만 지정해야 합니다.

## ETHERNET CONNECTION

On the lower left part of the instrument there is a RJ45 connector for Ethernet.

Features:

Transmission speed 10 Mbps

Network compatible with 10/100/1000 Base-T

TCP Ethernet protocols, Modbus/TCP, UDP, IP, ICMP, ARP

TCP server communication mode

LED indicators (2) Presence of Ethernet and communication/diagnostics line

Buffer size 256 bytes

Connection Time-out Min 30 seconds - Max 90 seconds

Link Time-out (cable disconnected) 30 seconds

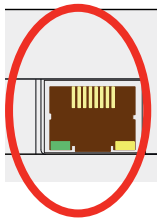

To connect to the MASTER, use a standard twisted pair Ethernet cable with RJ45 connector.

The RJ45 Ethernet connection cable has a variable maximum length, depending on the type of cable. A common Cat5 shielded cable can have a maximum length of about 180 m.

- You can connect the Ethernet communication port directly to the PC, without having to go through other network devices (routers, switches, hubs, LAN-bridge or the like), but special RJ45 cables must be used, called "crossover."

- Normally cables are the "direct" type and allow connection to network devices such as routers or hubs, but not direct connection to two PCs (even if there are currently network cards with auto-sensing technology, which recognize the type of cable and the type of connection, allowing direct PC-PC connections as well as using non cross-over cables).

- On side are diagrams of the two types of cables mentioned and their connection diagram.

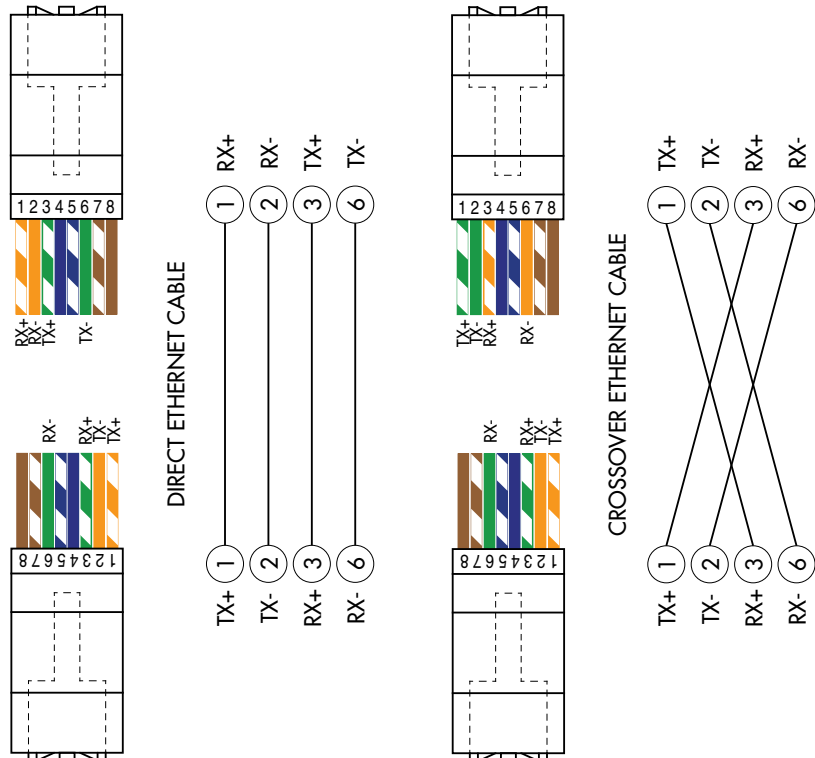

PIN	DESCRIPTION
1	TX+
2	TX-
3	RX+
4	
5	
6	RX-
7	
8	

## ETHERNET / IP CONNECTION

이더넷/IP는 이더넷 네트워크를 기반으로 하는 실시간 산업 프로토콜입니다.

RJ45 커넥터가 두 개 있어 동일한 네트워크에 여러 기기를 연결할 수 있습니다.

Refer to the previous page for connection notes and warnings.

Features:

10 and 100 Mbit operation, Full and Half Duplex

Modbus-TCP server

Up to 128 bytes of I / O fieldbus in every direction.

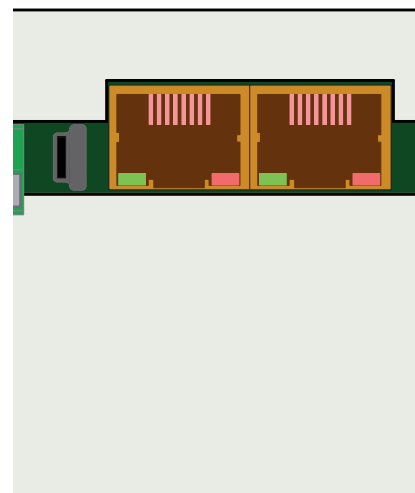

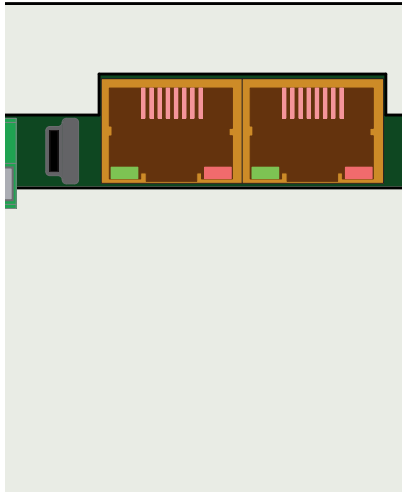

## PROFINET CONNECTION

프로피넷 커넥터는 이더넷 인터페이스와 동일한 RJ45입니다. 동일 네트워크에 여러 계측기를 연결할 수 있도록 두 개의 RJ45 커넥터가 제공됩니다.

연결 시 주의 사항 및 경고는 이전 페이지를 참조하십시오.

Features:

PROFINET IO Real Time (RT) communications

Modbus-TCP server

Up to 128 bytes of I/O fieldbus in every direction.

## ETHERCAT CONNECTION

EtherCAT은 이더넷 네트워크를 기반으로 하는 실시간 산업용 프로토콜입니다.

EtherCAT 프로토콜을 사용하려면 RJ45 커넥터가 입력(IN)과 출력(OUT) 기능을 모두 갖추어야 합니다.

DAT1400 기기를 직렬로 연결할 경우, 마스터는 첫 번째 DAT1400의 입력 단자에 연결되고, 첫 번째 DAT1400의 출력 단자는 다음 DAT1400의 입력 단자에 연결되는 식으로 연결됩니다.

연결 관련 참고 사항 및 주의 사항은 이전 페이지를 참조하십시오.



## MAC ADDRESS IN INSTRUMENTS WITH INDUSTRIAL FIELDBUS ETHERNET.

산업용 이더넷 프로토콜(Profinet, EthernetIP, EtherCAT 등)을 사용하는 Hilscher 모듈이 설치된 계측기에는 그림과 같이 커넥터 아래에 라벨이 붙어 있습니다.

이 라벨에는 모듈의 MAC 주소(빨간색 상자), 모듈 식별 번호(파란색 상자) 및 MAC 주소가 포함된 QR 코드가 표시되어 있습니다. 이 QR 코드는 스마트폰 앱(예: Google Play 스토어에서 "QR 코드 리더" 검색)을 사용하여 읽을 수 있습니다.

## PROFIBUS DP CONNECTION

Pin	Signal	Description
1	-	-
2	-	-
3	B line	+RxD/+TxD, level RS485
4	RTS	Request to send
5	GND	Ground (isolated)
6	+ 5V Bus Output	+5V termination (isolated)
7	-	-
8	A line	-RxD/-TxD, level RS485
9	-	-
Housing	Cable shield	Internally connected to protective earth according to Profibus specification

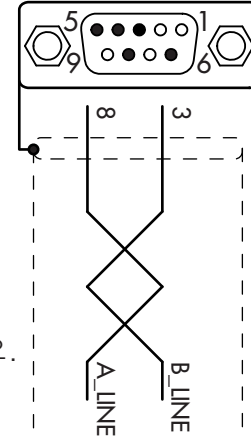

프로피버스 마스터에 연결하려면 표준 프로피버스 케이블을 사용하십시오.

케이블의 일반적인 임피던스는 100~130옴 ( $f > 100\text{kHz}$ ) 범위여야 합니다. 케이블 용량(도체 간 측정)은 60pF/m 미만이어야 하며, 최소 케이블 단면적은  $0.22\text{mm}^2$  이상이어야 합니다.

Profibus-DP 네트워크에서는 필요한 성능에 따라 A형-B형 케이블을 사용할 수 있습니다. 다음 표는 사용할 케이블의 특징을 요약한 것입니다.

Specification	Type A Cable	Type B Cable
Impedance	from 135 to 165 ohm ( $f = 3 - 20 \text{ MHz}$ )	from 100 to 300 ohm ( $f > 100 \text{ kHz}$ )
Capacity	< 30 pF/m	< 60 pF/m
Resistance	< 110 ohm/km	-
Conductor cross section	> 0,34 mm <sup>2</sup>	> 0,22 mm <sup>2</sup>

The following table shows the maximum length of the wires line with cable type A and type B, function of the different communication speed required:

Baud rate (kbit/s)	9.6	19.2	187.5	500	1500	3000	6000	12000
Cable A length (m)	1200	1200	1000	400	200	100	100	100
Cable B length (m)	1200	1200	600	200	-	-	-	-

For a reliable operation of the Fieldbus, should be used a line termination at both ends.

In the case of multiple UWT 6008 instruments, use the line termination at only one instrument.

For configuring the instrument, the GSD file is available (hms\_1810.gsd) that must be installed in the master.



## FRONT PANEL OF THE INSTRUMENT

UWT 6008 트랜스미터는 128 x 64 픽셀 그래픽 LCD 디스플레이를 사용하여 모든 중량 정보와 입력 및 출력 상태를 표시합니다. 또한, 다양한 프로그래밍 절차에 따라 디스플레이를 사용하여 메모리에 입력할 매개변수를 프로그래밍할 수 있으며, 수행 중인 작업 유형을 나타내는 메시지를 표시하여 작업자가 기기를 관리하고 프로그래밍하는 데 도움을 줍니다.

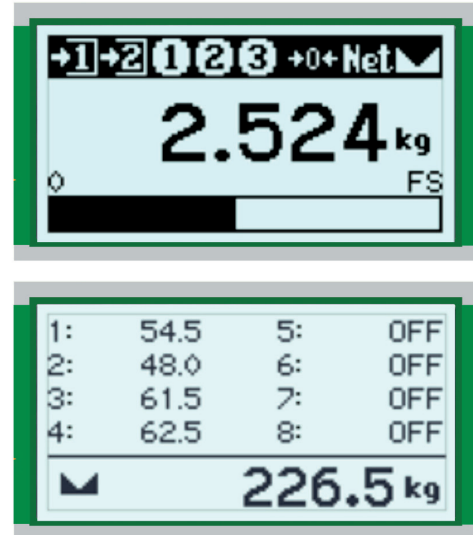

설정 매개변수는 전면 키를 사용하여 쉽게 접근하고 수정할 수 있으며, 이 키를 사용하여 설정을 선택, 수정, 확인 및 저장할 수 있습니다.

### STAND-BY FUNCTION



디스플레이는 대기 모드로 전환될 수 있으며, 이 경우 디스플레이 밝기가 줄어들고 키패드가 잠깁니다. 기기의 다른 모든 기능은 정상적으로 작동합니다.

















대기 모드 활성화/비활성화에 관한 항목을 참조하십시오.











## USING THE KEYPAD





이 기기는 4개의 키로 구성된 정전식 키패드를 통해 프로그래밍 및 제어되며, 모든 키는 두 가지 기능을 수행합니다. 두 키 기능 중 하나는 현재 작동 상태에 따라 기기에서 자동으로 선택됩니다. 일반적으로 프로그래밍 메뉴는 # 키와 \$ 키를 사용하여 항목을 스크롤하고, 8 키를 사용하여 관련 하위 메뉴 또는 프로그래밍 가능한 설정에 접근하며, NO 키를 사용하여 메뉴를 종료하거나 상위 레벨로 돌아갑니다.

SYMBOL	DESCRIPTION
	Short press on the single key. The buzzer gives a short beep
	Long press on a single key. The buzzer gives a short beep to the pressure and a long sound after 2 seconds

KEY	FUNCTIONS DURING WEIGHT DISPLAY
 	Access to the set points value programming menu
 	Display selection (gross weight, net weight).
 	Switches the display (Total / Single cells / percentage actual load / load cell signal).
 	Sending the weight string via the serial line.
  + 	(Press for 3 sec) Access to set-up menu.
 	Performs semi-automatic zeroing
  + 	Enter and exit the standby mode



KEY	FUNCTION DURING THE PROGRAMMING MENU NAVIGATION
	It selects the next menu.
	It selects the previous menu.
	It exits the programming menu or returns to the upper level.
	It accesses the relative sub-menu or programming or confirms the selected parameter.

KEY	FUNCTION DURING SETTING OF THE NUMERICAL VALUES
	It increases the value of the selected digit.
	It decreases the value of the selected digit.
	Select the next digit. It exits without saving the changes.
	It ends composition and saves the value.
	It resets all the digits.



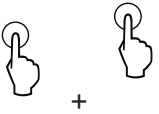

KEY	FUNCTION WHILE SETTING SUGGESTED VALUES
	It selects the next value.
	It selects the previous value.
	It confirms and stores the displayed value.
	It exits without saving the changes.

Pressing the key  always results in a return to the previous menu.

## KEYBOARD LOCKING/UNLOCKING FUNCTIONS

OPERATION	DESCRIPTION
	Keyboard Lock - The keys are disabled until released. The display goes into low power mode. By switching the instrument on and off the instrument automatically unlocks.
	Keyboard Unlock - The keys are reactivated and the brightness of the display reverts to standard.

## EXITING THE CONFIGURATION MENU

Press the  key to go back to the main menu. Press the  key again until "STORE?" is displayed. Press the  key to save and display the weight or press the  key to go back to the setup menu.

## **INFO DISPLAY**

When the instrument is switched on, the display test is performed, then the main features of the instrument are displayed: software, version, number of programmed channels and Fieldbus present. Codes to be notified in the event of a request for assistance.

When a programming procedure is not in progress, the display shows in the upper part the status of the inputs and outputs, the weight status and the stability. In the central part of the display the weight and the relative unit of measurement are displayed, while in the lower part a bargraph indicates the current weight with respect to the full scale set:

When is not in progress a programming procedure, the display shows the weight measured in kilograms. Under certain conditions, the following messages are reported:













### **NOTIFICATION OF ERRORS**

Any system error messages are displayed in the central part of the display instead of the weight.

## OPERATING FUNCTIONS

Once calibrated, the display shows the current weight whenever it is switched on.

The following are the possible operations that can be carried out from the keyboard when viewing the weight of the instrument.

KEY	OPERATION	FUNCTION
		Display of Gross Weight to Net Weight.
		Display of the peak. Keep pressed to exit from peak function
		Net Weight being displayed: Auto-tare.
		Gross Weight being displayed: Semi-Automatic zero.
		Transmission of a string from serial (only protocol on-demand)
		Set-Point function programming.
  +		Entry into the Programming Menu

### GROSS WEIGHT / NET WEIGHT DISPLAY

Press the  key to toggle between the gross weight and the net weight and vice versa. The value displayed is signalled by the NET LED (lit: net weight). If the tare is not entered, the net weight is equal to the gross weight.

In the case of negative weight, the minus sign is shown before the digit.

### RESETTING THE WEIGHT AND AUTO-TARE

These two functions are performed by the 0 key .

When the instrument is in the "Net" operating mode ("NET" LED on) the 0 key  performs the auto-tare function.

When the instrument is in the "Gross" operating mode ("NET" LED off) the 0 key  performs the gross weight resetting function.

## ZERO SETTING

The reset command of the gross weight is used to correct for small zero shifts of the weighing system during normal operation.

Normally these zero shifts are due to thermal drifts or to residues of material that accumulate on the weighing system over the time.

To run the command, it is necessary for the instrument to be under "Gross" conditions ("NET" indication off) and for the deviation of the weight with respect to the zero of the scale (the one performed with the zero calibration procedure) does not exceed (in positive or negative) the number of divisions set in the "O BAND" parameter (within the PARAM menu).

The reset command of the gross weight is not executed if occurs even one of the following conditions:

- Unstable weight (with weight stability control enabled). In this case, the reset command takes effect only if the weight stabilises within 3 seconds or if the the weight stability control is disabled ("MOTION " parameter equal to zero).
- Gross weight greater (in positive or negative) than the number of divisions set in the "O BAND" parameter, when the auto-zero set-point is not programmed.

The zero obtained with the gross weight resetting operation is retained in memory even after the instrument is turned off.

The gross weight reset operation can be repeated several times, but the number of divisions reset to zero is added from time to time, so when the total exceeds the limit value set in parameter "O BAND", zero setting can no longer be executed. In this case, it is necessary to calibrate the Zero.

Any automatic zero parameter setting when switching on (AUTO 0) reduces (or clears, in the case of "AUTO 0"> "O BAND") the range of action of the reset command.

## AUTO-TARE

Auto-tare is possible in the following conditions:

- Instrument in "Net" conditions ("NET" indication present)
- Positive gross weight.
- Gross weight not exceeding maximum capacity.
- Stable weight.
- Unstable weight. In this condition 2 cases must be distinguished:
  1. The weight stability control is enabled (the "MOTION" parameter (\*) must be other than zero): the command executed while the weight is unstable only has an effect if the weight stabilizes within 3 seconds after the command was given.
  2. The weight stability control is disabled (the "MOTION" parameter (\*) is equal to zero): the executed command takes effect immediately, even with unstable weight.

(\*) *The operating modes of the "MOTION" parameter are described in the relevant paragraph.*

The auto-tare is retained in memory even after the instrument is turned off.

## TEST FUNCTIONS - RS232 AND RS485

The test consists of sending the string received from its serial line (echo) and the display of the number of strings received and the number of characters received in the last string.

00C= 00

## TEST FUNCTIONS - ANALOGUE OUTPUT TEST

Once in the analog test function, the following message will appear:

0% where 0 indicates the output value (in current or voltage based on that selected) expressed as a % of the full scale.

You can change this value from 0 to 100, with an interval of 10%, by pressing the 0 key.

Press the ZERO key to exit from the function.

## INPUT / OUTPUT TEST FUNCTIONS

Once in the IN OUT test function, the following IN-00. OUT-0000 will appear where 00 depends on the logic inputs mode, as shown in the table:

VALUE	MEANING
00	No active input
01	Input 1 active
10	Input 2 active
11	Inputs 1 and 2 active

In the same menu it is possible to enable or disable the outputs by pressing the 4 front buttons, each of which activates / deactivates a single output.

SET      FUN      ZERO      PRG  
 OUT1    OUT2    OUT3    OUT4

Hold on the ZERO key to exit from the function.

## PROGRAMMING THE WEIGHT SET-POINTS

The set-points are compared with the weight to drive the relative logic output. The comparison criterion is defined during set-up of the logic inputs/outputs (see the relevant section).

To access the Set points setting, press the SET key while viewing the weight

MENU	MESSAGE	DESCRIPTION	TYPE	DEFAULT	RANGE	IND.FIELD BUS
Setpoint	SETPOINT 1	Sets value of Set-point 1	Com.	0	0÷Capacity	201 (MSW) 202 (LSW)
	SETPOINT 2	Sets value of Set-point 2	Com.	0	0÷Capacity	203 (MSW) 204 (LSW)
	SETPOINT 3	Sets value of Set-point 3	Com.	0	0÷Capacity	205 (MSW) 206 (LSW)
	SETPOINT 4	Sets value of Set-point 4	Com.	0	0÷Capacity	207 (MSW) 208 (LSW)

The set-points are compared with the weight to drive the relative logic output. The comparison criteria is established in the set-point set-up procedure.

When the weight is not detectable or out of range, all the outputs are disabled (contact open or closed depending on the MODE; see the relevant chapter).

During the step of setting the set-points, both outputs are disabled. If the set-point value in the memory is 0, the relative output is never enabled, regardless of the set-up of the selected set-points.

## **WEIGHT ACQUISITION**

The weight can be printed or sent to the serial port / fieldbus (depending on the setting of the communication ports), in the following ways:

- In automatic mode (in the event of selecting the "automatic" serial communication protocol).
- Through the instrument keyboard (pressing the PRG key, in the event of selecting the "on demand" serial communication protocol).
- From the external input (in the event of selecting the "on demand" serial communication protocol and the "data transmission on demand" operation selected on at least one input).
- Through the serial line (in the event of selecting the "slave" serial communication protocol), by sending the weighing execution command.
- Through the fieldbus, using the weighing execution command in the register command.

The following are the conditions for weight acquisition:

- Stable weight (or stabilised within 3 seconds from the command).
- Since the last acquisition carried out, the weight has undergone a change of at least 20 divisions (weight difference).
- Gross weight equal or greater than the minimum weight (20 divisions) and less than the maximum capacity.
- Net weight not zero.



# SETTING

## GENERAL DATA





UWT 6008의 모든 기능은 다음 페이지에 나와 있는 간단한 설정 메뉴를 통해 활성화 및 수정할 수 있습니다. 선택하거나 활성화한 모든 설정은 송신기의 전원을 끈 후에도 메모리에 저장됩니다.



UWT 6008은 기본 설정으로 사전 구성되어 있습니다. 다음 페이지에는 각 매개변수의 "기본값"이 나와 있습니다.





최초 현장 설치 시 표시되는 무게가 정확하게 나타나도록 몇 가지 매개변수를 변경해야 합니다(이론적 교정).

이 작업은 계량 시스템 데이터를 제공하여 공장에서 요청할 수 있습니다.

설정 메뉴의 설정은 전면의 키 또는 제공된 "OPTIMATION" 유틸리티 소프트웨어를 사용하여 변경할 수 있습니다.

KEY	FUNCTION WHILE MAIN MENU PROGRAMMING
	It selects the next menu.
	It selects the previous menu.
	It exits the programming menu or returns to the upper level.
	It accesses the relative sub-menu or programming or confirms the selected parameter.

KEY	FUNCTION WHILE SETTING SUGGESTED VALUES
	It selects the next value.
	It selects the previous value.
	It confirms and stores the displayed value.

KEY	FUNCTION WHILE SETTING NUMERIC VALUES
	It increases the value of the flashing digit.
	It decreases the value of the flashing digit.
	It goes to the next digit.
	It confirms and stores the displayed value.

## CHANGING AND ENTERING THE PARAMETERS:

To access the setup menu, press the PRG key and then the SET key and hold them down simultaneously for 3 seconds.

The following screen appears:



Access by confirming your choice with the PRG key.

MESSAGE	NAME	DESCRIPTION
INFO	Information	Parameter menu can be viewed for identification of the instrument and its configuration.
TEST	Test	Menu of test procedures for operation of the instrument hardware.
SETUP	Setup	Menu of programmable parameters which determine the operation of the instrument

## INFO MENU

MENU	MESSAGE	NAME	DESCRIPTION	TYPE
INFO	FIRMWARE	Firmware code	Indication of installed Firmware code	Vis.
	FULL SCALE	Full scale of the instrument	Indication of the full scale value set	Vis.
	COM ADDRESS	Number of address for serial line	Indication of the number of address for serial line	Vis.
	FIELDBUS*	Fieldbus present	Indicates the type of Fieldbus configured	Vis.
	ADDRESS*	Fieldbus address	Indicates the Fieldbus address set. <b>This menu item is displayed only in the RS485 and PROFIBUS configurations.</b>	Vis.
	IP ADDRESS*	Fieldbus IP address	Indicates the IP Fieldbus address set. <b>This menu item is displayed only in the PROFINET and ETHERNET/IP configurations.</b>	Vis.
	SUBNET.*	Subnet Mask Fieldbus	Indication of the subnet mask Fieldbus set. <b>This menu item is displayed only in the PROFINET and ETHERNET/IP configurations.</b>	Vis.
	ANALOGIC	Analog Output Configuration	Indicates the presence and type of analogue output (Not present - Unipolar - Bipolar)	Vis.
	MEMORY*	Optional Memory Configuration	Indicates the presence and type of memory (None - Alibi memory - µSD card)	Vis.

\* Parameters present only if the corresponding hardware option is installed

In the case of PROFINET field bus: the parameters IP address and Subnet Mask are programmable by PLC and are updated in this menu only when the instrument is switched on. Following a change in these parameters from the PLC, the instrument must be switched off and on again to display the correct value.

It is important to remember that even if you set the parameters IP address and subnet mask in Temporary mode, these parameters are not automatically updated in the instrument. Moreover, when the instrument is switched off and then on again, these parameters will all be set to 0.0.0.0.

## TEST MENU

MENU	MESSAGE	NAME	DESCRIPTION	TYPE
TEST	CELL SIGNAL	Cell signal	Display of the signal in mV/V in input to the instrument	Vis.
	WEIGHT X10	Resolution x10	Display of the weight with a resolution 10 times greater than that set	Vis.
	POWER SUPPLY	Power supply voltage	Display of the supply voltage measured by the instrument	Vis.
	IN/OUT	I/O test	I/O test with simultaneous display of inputs and outputs (See specific description)	
	RS 232	Test RS232	Transmission and receipt test (See specific description)	
	RS 485	Test RS485	Transmission and receipt test (See specific description)	
	ANALOG	Analog output test	Test procedure with manual activation of the output value (See specific description)	
	MEMORY	Test of the memory (when present)	Automatic operation test of the additional memory	Test.

## SETUP MENU

MENU	SUB MENU	NAME
SETUP	CALIBRATION	Calibration Settings
	ANALOG OUT(**)	Analog output settings
	CONNECTIONS	Serial ports and fieldbus settings
	IN/OUT	Logic Output and Input settings
	PARAMETERS	Weighing meteorological parameter settings
	FILTER	Filter Settings
	FUNCTIONS	Functional Features settings
	CLOCK(**)	Date and Time setting

(\*\*) This menu is displayed only in case of presence of relative hardware options.

On exiting the setup menu, if changes were made to the parameters, the message STORE, is displayed which is confirmed with PRG

## CONFIGURATION PARAMETERS

All the parameters that can be set are described in the following pages. At the end of each parameter description, where present, the fieldbus address corresponding to the parameter is shown. If the parameter is the selectable type, the value to be entered in the register for the desired selection is shown between "[ ]".

### CALIBRATION MENU

#### NUM. OF CELLS

##### **NUMBER OF LOAD CELLS [1101÷1102]**

Number of load cells connected to the instrument

*Values that can be selected:*

1 ÷ 8

*Default: 4*

#### UNIT

##### **MEASUREMENT UNIT [1101÷1102]**

electing the unit of measurement used, you can set the desired unit

*Values that can be selected:*

g - kg - N - kN

*Default: kg*

#### RESOLUTION

##### **DIVISION VALUE [1101÷1102]**

Value of a single division, expressed in kg. The ratio between the capacity of the system and the division value represents the resolution of the system (number of divisions).

Following the change of the division value, if the maximum capacity is not changed, calibration of the weight is corrected automatically.

*Values that can be selected:*

0.0001 - 0.0002 - 0.0005

0.001 - 0.002 - 0.005

0.01 - 0.02 - 0.05

0.1 - 0.2 - 0.5

1 - 2 - 5

10 - 20 - 50

*Default: 1*

## CAPACITY

### **CAPACITY OF THE LOAD CELLS [1103-1104]**

이 값은 측정 단위로 표현된 로드셀의 정격 용량 값의 합에 해당하는 값을 정의합니다. 로드셀이 하나만 있고 고정 지지대가 "N"개인 시스템의 경우, 전체 지지대 수에 대한 로드셀의 용량 값을 입력하십시오. 이 값은 계량 시스템의 최대 측정값을 나타냅니다. 매개변수 값이 변경되면 이론 용량 값이 다시 계산됩니다.

*Values: from 1 to 999999*

*Default: 0*

## SENSITIVITY

### **SENSITIVITY OF THE LOAD CELLS [1105]**

로드셀의 평균 감도에 해당하는 값을 mV/V 단위로 설정하십시오. 기기는 0.0~4mV/V 범위의 값을 허용합니다. 값을 설정하지 않으면 기본값인 2mV/V가 사용됩니다.

민감도 값의 변화에 따라 이론적 가중치 값이 재계산됩니다.

*Values: from 0.0000 to 4.0000 mV/V*

*Default: 2.0000*

## FULL SCALE

### **CAPACITY OF THE WEIGHING SYSTEM [1301-1302]**

계량 시스템의 유효 용량(순용량)을 프로그래밍합니다. 값 범위: 0 ~ 로드셀 용량

*Default: 0*

## DEAD LOAD

### **FIXED TARE OF WEIGHING SYSTEM [1106-1107]**

계량 시스템의 고정 용기 무게 값 프로그래밍 값 범위: 0 ~ 용량 값

*Default: 00000*

## BALANCING

### **BALANCING**

이 기능은 플랫폼의 각도를 보정하는 데 사용되며, 정션 박스에 위치한 조정 트리머를 사용하지 않고도 플랫폼의 네 모서리를 동일하게 이동시켜 무게 차이를 발생시키지 않습니다.

*Values: -*

*Default: -*

## CALIBRATION

### **SELECTING THE CALIBRATION TYPE**

교정 유형을 선택합니다. 확인 후 다음 절차 중 하나가 시작됩니다.

## DEAD WEIGHT

### **DEAD WEIGHT TYPE CALIBRATION [501÷503]**

시료 무게를 사용하여 최대 5개의 선형화 지점까지 영점 교정 및 전체 스케일 조정이 가능합니다.

## DATA TABLE

### **TABLE TYPE CALIBRATION [1151÷1172]**

최대 5개의 교정점을 수동으로 프로그래밍할 수 있습니다. 이 값들은 시료 무게를 이용한 선형화 절차에서 얻은 값에 해당합니다. 따라서 시료 무게를 사용하여 만든 교정값을 복사할 수 있습니다.

## **PARAMETERS DISPLAYED ONLY DURING METRIC OPERATION**

### G-CALIBRATION

#### **CALIBRATION LOCATION GRAVITY [1108-1109]**

*교정 위치 중력 [1108-1109]*

*교정이 수행되는 위치의 중력을 프로그래밍합니다. 값: 9.77000 ~ 9.84000*

*Default: 0*

### G-USE

#### **GRAVITY OF LOCATION OF USE [1110-1111]**

*사용 위치의 중력 [1110-1111]*

*기기가 사용될 위치의 중력을 프로그래밍합니다. 값: 9.77000 ~ 9.840000*

*Default: 0*

## LOAD CELLS BALANCING

최소 2개의 로드셀을 사용해야만 해당 절차를 수행할 수 있으며, 그렇지 않으면 메뉴가 활성화되지 않습니다.

### AUTOMATIC PROCEDURE

자동 균형 조정 절차를 수행하려면 계량 시스템을 구성하는 로드셀 위로 이동시킬 무게추가 있어야 합니다.

PRG 키를 눌러 메뉴에 들어가면 디스플레이에 AZZERA?가 표시됩니다. PRG 키를 눌러 확인하십시오. 디스플레이에 00000이 표시됩니다. 시료 무게 값을 입력하고 PRG 키를 눌러 확인하십시오. 이 시점에서 기기는 1번 로드셀을 가리킵니다.

ENTER 키를 눌러 시료 무게를 설정한 다음, 마지막 로드셀까지 순차적으로 진행하십시오.

로드된 셀이 올바르지 않거나 절차가 성공적으로 완료되지 않으면 기기에 오류 메시지가 표시됩니다. 이 경우 문제를 해결하고 절차를 다시 시도하십시오.

### BALANCING FACTOR

각 로드셀의 균형 계수는 해당 메뉴에 접근하여 선택한 로드셀의 값을 변경함으로써 수동으로 변경할 수 있습니다.

값은 0.1000에서 9.9999까지 설정할 수 있으며, 기본값은 1.0000입니다.



## **CONFIGURATION/CALIBRATION EXAMPLE**

Set the parameters listed above to perform theoretical calibration of the Full Scale of the UWT 6008. This procedure must be completed with calibration of the zero-point as described later on. The procedure ensures good precision of the system (maximum error <1% FS) when there are no mechanical problems.

When you change the RESOLUTION selection, calibration of the full-scale is automatically recalculated. Selections incompatible with the calibration parameters or with the calibration value saved in the memory are not accepted.

A tank must be weighed, of an unladen weight of 750 Kg and capacity 1000 litres, containing a product with specific weight 1.3 Kg/dm<sup>3</sup> the weight of which needs to be read with a display resolution 0.2 Kg.

Before proceeding with configuration it is required to ensure the load cells are connected correctly to the unit and the tank is empty, the parameters may then be set.

Use:

3 load cells 1000 Kg capacity

Sensitivity respectively 2.0015, 2.0008 and 1.9998 mV/V (average value = 2.0007 mV/V)

Set the following figures in configuration parameters:

NUM. OF CELLS = 3

RESOLUTION = 0.2

CAPACITY = 3000

SENSITIVITY 1 = 2.0015

SENSITIVITY 2 = 2.0008

SENSITIVITY 3 = 1.9998

FULL SCALE = 1500

DEAD LOAD = 0

Ensure the value read in parameter SIGNAL of the menu TEST corresponds to the tare weight of the system according to the following proportion:

$$3000:2.0007=750:X$$

Where X is the value of the signal expressed in mV/V corresponding to the theoretical value of the empty tank weight- The value should be about 0.5 mV/V

At this stage one may proceed with calibration described in the following paragraph or exit the configuration menu saving the data entered.

The instrument should indicate the value corresponding to the unladen tank weight (e.g. 756.8).

It is possible to enter the configuration menu again and enter the value of the weight read in parameter DEAD LOAD and enter 756.8

Exit the configuration menu again after saving the data.

For greater precision arrange sample weights or pre-weighed material on a certified scale and proceed with calibration as described in the following paragraph.

# CALIBRATION OF SAMPLE WEIGHTS

The calibration procedure described below should be carried out using sample weights and/or a sample product pre-weighed on a weighing system.

Before proceeding with calibration of the full scale, always perform zero calibration.

During the calibration phase, the weight is shown on the display in alternation with the text CAL.

**WARNING:** Switching off the instrument without exiting the set-up menu cancels any changes made during the programming process.

N.B. If linearity errors are shown after calibration, verify that the weighed structure is completely free of mechanical constraints.

## ZERO CALIBRATION

Perform this operation with the scale unloaded (including the fixed tare), and when the weight is stable. The zero value of the system is set by pressing the key FUN.

The weight displayed is reset and the display shows CAL and 0. in alternation. This operation can be repeated at will. Press and hold the PRG key to return to the CALIBRAZIONE menu.

## CALIBRATION OF THE FULL SCALE

Before calibration, put the sample weight on the scale and wait for stabilisation; the display shows a weight value.

To correct the displayed weight press the SET key. All the digits to 0 appears on the display with the the first digit on the left flashing. Using the arrow keys, enter the actual weight loaded on the scale starting with the first flashing digit. Move to the next digit by pressing PRG. Pressing the PRG key to confirm the last digit (far right) corrects the weight. SAVE and then CAL are shown in alternation to the actual weight value entered on the display.

If the set value is higher than the resolution offered by the instrument, the weight is not accepted and an error message appears on the display for a few seconds.

This procedure can be repeated.

Press and hold the PRG key to return to the CALIBRAZIONE menu.

## LINEARISATION PROCEDURE

Sample weights linearisation: (SET key long press) up to 5 linearisation points are possible on positive scale. The progression of linearisation points is displayed alternately to the current weight. Press the SET key to set the sample weight value loaded and stabilised. Upon confirmation, you return to the weight value; to set the next linearization point, press the SET key again. If 0 is set the value is not saved. To end the procedure press and hold the PRG key. It is possible to save a number of points less than 5.

The calibration operations can always be repeated.

When programming the sample weight, values greater than the full scale, or lower than the previous point, or when the weight is not stable, are not accepted. If the entered value is accepted, the next step is shown, otherwise still the same.

The linearisation points are automatically reset by any change of the theoretical calibration data or if a full-scale calibration is performed.

## TABLE CALIBRATION

It allows you to manually program up to five calibration points, in addition to zero. The values corresponding to those resulting from the linearisation procedure with sample weights. This way you can view the values automatically determined with this procedure or modify and program them in accordance with predetermined values.

SUBMENU	MESSAGGIO	NAME	DESCRIPTION	TYPE
TABLE	GET 0.	Acquire the Zero Signal	Acquisition function of the signal corresponding to the zero scale expressed in mV/V	
	0 SIGNAL	Zero signal	Signal value in mV / V corresponding to the zero scale	Com.
	P1 VALUE	Weight point 1	Weight value corresponding to the 1st calibration point	Com.
	P1 SIGNAL	Signal point 1	Signal value in mV/V corresponding to the 1st calibration point	Com.
	P2 VALUE	Weight point 2	Weight value corresponding to the 2nd calibration point	Com.
	P2 SIGNAL	Signal point 2	Signal value in mV/V corresponding to the 2nd calibration point	Com.
	P3 VALUE	Weight point 3	Weight value corresponding to the 3rd calibration point	Com.
	P3 SIGNAL	Signal point 3	Signal value in mV/V corresponding to the 3rd calibration point	Com.
	P4 VALUE	Weight point 4	Weight point 4 Weight value corresponding to the 4th calibration point	Com.
	P4 SIGNAL	Signal point 4	Signal point 4 Signal value in mV/V corresponding to the 4th calibration point	Com.
	P5 VALUE	Weight point 5	Weight point 5 Weight value corresponding to the 5th calibration point	Com.
	P5 SIGNAL	Signal point 5	Signal point 5 Signal value in mV/V corresponding to the 5th calibration point	

The programmed to zero are not considered. The calibration data sheet is automatically cancelled when a new theoretical calibration is carried out or with sample weights.

After the execution of the zero signal acquisition function, using  key, the signals in the table are recalculated. At each signal value an offset is added, obtained from the difference between the new acquired zero signal and the old zero signal value.

### EXITING THE CALIBRATION MENU

To exit the CALIBRATION press the menu key , press until the text STORE? appears on the display. Press PRG to save calibration and exit the setup menu.

It is possible to clear the zero and full scale calibrations.

 +  delete zero calibration.  +  delete the full scale calibration.

## ANALOG - ANALOG OUTPUT PARAMETERS (OPTIONAL)

### RANGE

#### ANALOG OUTPUT RANGE [1506]

Select the analogue output range.

Selectable setting:

0÷10 Vdc [0]

0÷5 Vdc [1]

4÷20 mA [2]

0÷20 mA [3]

Default: 0÷10 Vdc

### MODE

#### ANALOG OUTPUT OPERATION MODE [1505]

Selection of the value to be associated to the analogue output, corresponding to the net weight, gross weight or peak value.

Selectable setting:

NET [0]

GROSS [1]

PEAK [2]

HOLD [3]

Default: NET

### ZERO

#### ANALOG OUTPUT ZERO VALUE [1501-1502]

Analogue value to be subtracted referred to the full scale of the analogue output.

### FULL SCALE

#### FULL SCALE [1503-1504]

It is the weight corresponding to the analog output full scale.

Value settable from 0 to Capacity

Default: Capacity

### SET ZERO

#### ZERO OFFSET REGULATION

Measure the analogue output value with a multimeter to perform the zero (0) calibration.



Use the keys  and  to regulate the analogue output. Press and hold the key for rapid change.

Press key  to go back to the ANALOG menu.

## SET FS

### **FULL SCALE OFFSET REGULATION**

Measure the analogue output value with a multimeter to perform the full scale (FS) calibration.

Use the keys  and  to regulate the analogue output. Hold the key for a quick change.

Press key  to go back to the ANALOG menu.

This procedure is available to the user for adjustment, for each selectable range. In the case of a full reset of the setup memory, they are restored values to the factory calibration.

## SERIAL COMMUNICATIONS PARAMETERS

This menu makes it possible to configure the RS232, RS485 serial ports and FIELDBUS:

### RS232

#### MODE

##### RS232 OUPUT MODE

Selecting the value transmitted on output RS 232.

*Values that can be selected:*

NET

GROSS

PEAK

*Default: NET*

#### DATA

##### DATA OUPUT MODE

Selecting the data transmitted on output RS 232.

*Values that can be selected:*

SINGLE WEIGHT

TOTAL WEIGHT

*Default: TOTAL WEIGHT*

#### PROTOCOL

##### RS232 PROTOCOL

It defines how to use the RS232 serial port:

*Values that can be selected:*

**None:** *Serial communication OFF*

**Continue:** *Continuous transmission of the weight string. It can be used, for example, to drive a weight repeater. See details in the relevant section.*

**On demand:** *When the Operator presses the relative button on the front or uses Input 2, a weight string is sent. The command is accepted if the weight is stable. Between two consecutive transmissions, variation of the weight must be at least equal to 20 divisions.*

**Automatic:** *A weight string is sent automatically when the weight stabilises at a value above the minimum weight (20 divisions).*

**Slave:** *ASCII protocol. See details in the relevant section.*

**Print:** *When the operator presses the key on the front or by Input, a weight string is transferred. The command is accepted if the weight is stable. Between two successive transmissions, the weight must have a variation of at least 20 divisions.*

*Default: Nessuno*

## BAUD RATE

### **RS232 BAUD RATE**

Defines the baud rate of serial port RS232.

The value must be set at the same value as PC/PLC or remote display.

*Values that can be selected:*

*1200 - 2400 - 4800 - 9600*

*19200 - 38400 - 57600 - 115200*

*Default: 9600*

## FRAME

### **RS232 PROTOCOL**

Type of frame. For the SLAVE protocol you cannot select 7-bit data format (E-7-1 e O-7-1):

*Values that can be selected:*

*n-8-1*

*n-8-2*

*E-7-2*

*E-8-1*

*o-7-2*

*o-8-1*

*Default: n-8-1*

## RS485

### MODE

#### RS485 OUTPUT MODE

Selecting the value transmitted on output RS 485.

*Values that can be selected:*

NET

GROSS

PEAK

*Default: NET*

### DATA

#### DATA OUPUT MODE

Selecting the data transmitted on output RS 485.

*Values that can be selected:*

SINGLE WEIGHT

TOTAL WEIGHT

*Default: TOTAL WEIGHT*

### PROTOCOL

#### RS485 PROTOCOL

It defines how to use the RS485 serial port:

*Values that can be selected:*

**None:** Serial communication OFF

**Continue:** Continuous transmission of the weight string. It can be used, for example, to drive a weight repeater. See details in the relevant section.

**On demand:** When the operator presses the relevant front key or via Input 2, a weight string is transmitted. The command is accepted if the weight is stable. Between two subsequent transmissions the weight must undergo a variation of 20 divisions.

**Automatic:** A weight string is sent automatically when the weight stabilises at a value above the minimum weight (20 divisions). Variation of the weight between two consecutive transmissions must be at least 20 divisions.

**Slave:** ASCII protocol. See details in the relevant section.

**Modbus:** MODBUS RTU Protocol See details in the relevant section.

*Default: Nessuna*

### BAUD RATE

#### RS485 BAUD RATE

Defines the baud rate of serial port RS485.

The value must be set at the same value as PC/PLC or remote display.

*Values that can be selected:*

1200

1200 - 2400 - 4800 - 9600

19200 - 38400 - 57600 - 115200

*Default: 9600*



## FRAME

### **RS485 PROTOCOL**

Type of frame. For the SLAVE or MODBUS protocol you cannot select 7-bit data format (E-7-1 e O-7-1):

*Values that can be selected:*

*n-8-1*

*n-8-2*

*E-7-2*

*E-8-1*

*o-7-2*

*o-8-1*

*Default: n-8-1*

## ADDRESS

### **RS485 ADDRESS**

Communication address of the serial port:

*Values from 1 to 32*

*Default: 1*

## PROFINET / ETHERCAT

### ABILITA FIELDBUS

#### FIELD BUS ENABLING

Enabling PROFINET / ETHERCAT fieldbus, if OFF error messages concerning FIELDBUS communication are never displayed:

*Values that can be selected:*

OFF

ON

*Default: OFF*

### INPUT AREA

#### INPUT AREA DIMENSION

Input area dimension for fieldbus (value expressed in Bytes).

*Values that can be selected:*

32, 64, 96, 128

*Default: 128*

### OUTPUT AREA

#### OUTPUT AREA DIMENSION

Output area dimension for fieldbus (value expressed in Bytes).

*Values that can be selected:*

32, 64, 96, 128

*Default: 128*

In case of PROFINET fieldbus, the XML configuration file "GSDML-V2.3-HILSCHER-NIC 50-RE PNS 32-20160122.xml" is provided. The size of the input and output areas set in the PLC (possible selections: 32, 64, 96 or 128 bytes) must correspond to the size of the input and output areas selected in the instrument (parameters "INP.REG." and "OUT .REG.").

The instruments are supplied with the parameter "Profinet Name" not configured and IP address set at 0.0.0.0.

In case of ETHERCAT fieldbus: the devices will be connected with ring type (according to EtherCAT specification), refer to the installation manual for the use of INPUT and OUTPUT ports.

4 different XML configuration file are provided:

"Hilscher NIC 50-RE V2.2 ECS Byte.xml 32" (32 bytes Input Area, 32 bytes of Output area).

"Hilscher NIC 50-RE V2.2 ECS 64 Byte.xml" (64 bytes Input Area, 64 bytes of Output area).

"Hilscher NIC 50-RE V2.2 ECS Byte.xml 96" (96 bytes Input Area, 96 bytes of Output area).

"Hilscher NIC 50-RE V2.2 ECS 128 Byte.xml" (128 bytes Input Area, 128 bytes of Output area).

In the PLC must be imported the file that matches the size of the input and output areas selected in the instrument (for example, if the instrument is set to InP.rEG.=128 and oUt.rEG.=128, the PLC has to be imported file "Hilscher NIC 50-RE V2.2 ECS 128 Byte.xml"). It could be import multiple files with different size, but in this case you can not run the automatic search function and configuration of the devices on the network.

# ETHERNET IP

## ABILITA FIELDBUS

### **FIELDBUS ENABLING**

Enabling ETHERNET IP fieldbus, if OFF error messages concerning Fieldbus communication are never displayed:

*Values that can be selected:*

OFF

ON

*Default: OFF*

## IP

### **IP ADDRESS**

ETHERNET IP protocol address

*Values from 0.0.0.0 to 255.255.255.255*

*Default: 0.0.0.0*

## SUBNET

### **SUBNET MASK**

ETHERNET IP protocol Subnet Mask.

*Values from 0.0.0.0 to 255.255.255.255*

*Default: 0.0.0.0*

## INPUT AREA

### **INPUT AREA DIMENSION**

Input area dimension for fieldbus (value expressed in Bytes).

*Values that can be selected:*

*32, 64, 96, 128*

*Default: 128*

## OUTPUT AREA

### **OUTPUT AREA DIMENSION**

Output area dimension for fieldbus (value expressed in Bytes).

*Values that can be selected:*

*32, 64, 96, 128*

*Default: 128*

**In the case of IP ETHERNET fieldbus, the EDS configuration file "HILSCHER NIC 50-RE EIS V1.1.EDS" is provided. The size of the input and output areas set in the PLC (possible selections: 32, 64, 96 or 128 bytes) must correspond to the size of the input and output areas selected in the instrument (parameters "INP.REG." and "OUT .REG.").**

# ETHERNET

## MODE

### ETHERNET OUTPUT MODE

Selecting the value transmitted on output ETHERNET.

*Values that can be selected:*

NET

GROSS

PEAK

*Default: NET*

## PROTOCOL

### ETHERNET PROTOCOL

Selection of the communication type for Ethernet protocol:

*Values that can be selected:*

**None:** Serial communication OFF

**Continue:** Continuous transmission of the weight string. It can be used, for example, to drive a weight repeater. See details in the relevant section.

**On demand:** When the operator presses the relevant front key or via Input 2, a weight string is transmitted. The command is accepted if the weight is stable. Between two subsequent transmissions the weight must undergo a variation of 20 divisions.

**Automatic:** A weight string is sent automatically when the weight stabilises at a value above the minimum weight (20 divisions). Variation of the weight between two consecutive transmissions must be at least 20 divisions.

**Slave:** ASCII protocol. See details in the relevant section.

**Modbus:** MODBUS RTU Protocol See details in the relevant section.

*Default: Nessuna*

## IP

### IP ADDRESS

ETHERNET protocol IP address

*Values from 0.0.0.0 to 255.255.255.255*

*Default: 192.168.0.201*

## SUBNET

### SUBNET MASK

ETHERNET protocol Subnet Mask.

*Values from 0.0.0.0 to 255.255.255.255*

*Default: 255.255.255.0*

GATE

**GATEWAY**

ETHERNET protocol gateway.

*Values from 0.0.0.0 to 255.255.255.255*

*Default: 192.168.0.1*

PORTA

**PORT**

Communication port for ETHERNET protocol.

*Values from 1 to 65535*

*Default: 1800*

ETH.PRO..

# PROFIBUS DP

## ENABLING FIELDBUS

### **FIELDBUS ENABLING**

Enabling PROFIBUS DP fieldbus, if OFF error messages concerning Fieldbus communication are never displayed:

*Values that can be selected:*

OFF

ON

*Default: OFF*

## ADDRESS

### **PROFIBUS ADDRESS**

Programming the address used in the PROFIBUS protocol.

*Values: from 0 to 126*

*Default: 01*

## INPUT AREA

### **INPUT AREA DIMENSION**

Input area dimension for fieldbus (value expressed in Bytes).

*Values that can be selected:*

32, 64, 96, 128

*Default: 128*

## OUTPUT AREA

### **OUTPUT AREA DIMENSION**

Output area dimension for fieldbus (value expressed in Bytes).

*Values that can be selected:*

32, 64, 96, 128

*Default: 128*

**In the case of PROFIBUS fieldbus, the GSD configuration file "hms\_1810.gsd" is provided. The size of the input and output areas set in the PLC (possible selections: 32, 64, 96 or 128 bytes) must correspond to the size of the input and output areas selected in the instrument (parameters "INP.REG." and "OUT.REG.").**



# INPUT/OUTPUT PARAMETERS

## FUNCTION IN 1

### INPUT 1 FUNCTION

Selecting the function associated with input 1. [1401]

*Values that can be selected:*

**Zero:** *It calibrates to zero. [0]*

**Tare:** *It executes the automatic tare. [1]*

**Del.Tar:** *It cancels the tare. [2]*

**Peak:** *Reset of the peak function. [3]*

**Hold:** *Holds Acquired Weight. [4]*

**Send:** *Data transmission on demand. [5]*

**Log:** *Activates the datalogger function. [6]*

*Default: Zero*

## FUNCTION IN 2

### INPUT 2 FUNCTION

Selecting the function associated with input 2. [1402]

*Values that can be selected:*

**Zero:** *It calibrates to zero. [0]*

**Tare:** *It executes the automatic tare. [1]*

**Del.Tar:** *It cancels the tare. [2]*

**Peak:** *Reset of the peak function. [3]*

**Hold:** *Holds Acquired Weight. [4]*

**Send:** *Data transmission on demand. [5]*

**Log:** *Activates the datalogger function. [6]*

*Default: Zero*

## SET OUT 1

### SET FUNCTION OF SET POINT 1

## SET OUT 2

### SET FUNCTION OF SET POINT 2

## SET OUT 3

### IMSET FUNCTION OF SET POINT 3

## SET OUT 4

### SET FUNCTION OF SET POINT 4



## SET OUTX SUBMENU

### WEIGHT

#### ASSOCIATED WEIGHT

**Select in sequence 5 operating criteria of set-point 1, 2, 3, 4: [1403] [1410] [1417] [1424]**

Comparison with net weight, with gross weight or with peak. In the latter case the comparison is carried out with the last acquired peak value, even when the peak function is not active. The unbalance is activated if the relevant parameter is programmed. It represents the difference between the value measured by the cell and the average value.

*NET*        *The relay output is active in Net Weight mode. [0]*

*GROSS*     *The relay output is active in Gross Weight mode. [1]*

*PEAK*       *The relay output is active in Peak mode. [2]*

*PROCESS*   *The relay output is active when the instrument is working normally. [3]*

*UNBALANCED*     *The relay output is active when the load is unbalanced. [4]*

*Default: GROSS*

### LOGIC

**Selecting the output status if normally open or closed: [1404] [1411] [1418] [1425]**

*n.oPEn.*     *Relay 1 is normally open. [0]*

*n.CLoSE*    *Relay 1 is normally closed. [1]*

*Default: n.oPEn.*

### POLARITY

**Select if positive or negative values have to be compared. [1405] [1412] [1419] [1426]**

*PoSIt..*     *The output is operative with positive weight. [0]*

*nEGAt.*     *The output is operative with negative weight. [1]*

*ALL:*        *The output is operative both with positive and negative weight. [2]*

*Default: PoSt*

### STABILITY

**Select whether only stable weight values are to be compared or also unstable: [1406] [1413]**

*norMAL*     *Output 1 is active with unstable weight. [0]*

*StAbLE*     *The output is active with stable weight. [1]*

*Default: norMAL*

### HYSTERESIS

**SET-POINT 1 HYSTERESIS [1407] [1414] [1421] [1428]**

Hysteresis value with respect to the set-point

*Value: from 0 to Capacity*

*Default: 2*

## TIMER

### **SET-POINT 1 TIMING [1408] [1415] [1422] [14296]**

Value of time, in tenths of a second, during which, when the weight value set is exceeded, the output associated with set-point 1 remains enabled.

After this time, even if the weight value is still above the set-point, the output is automatically disabled.

The function is not active with programmed time equal to zero.

*Values: from 000 to 999*

*Default: 0*

## DELAY

### **SET-POINT 1 DELAY [1409] [1416] [1423] [1430]**

Value of time, in tenths of a second, after which, when the set weight value is exceeded, the output associated with set-point 1 is enabled.

The function is not active with programmed time equal to zero

*Values: from 000 to 999*

*Default: 0*

*After this time, even if the weight value is still beyond the set point, the output is automatically disabled.*

# WEIGHING PARAMETERS

The parameters in this menu permit adjustment of the times for acquisition and updating of the display and manual or automatic resetting by the transmitter.

## OPERATING MODE

### INSTRUMENT OPERATION

Selecting the operation of the instrument. In case of a change from FREE operation to METRIC operation, to confirm the setting authentication is required through the password of authorised personnel.

<i>Value</i>	<i>Variation</i>
<i>Free</i>	<i>Free operation. [0]</i>
<i>Trade</i>	<i>METRIC instrument operation. [1]</i>
<i>Default: Free</i>	

## STABILITY

### STABILITY OF WEIGHT [1303]

This parameter defines the number of divisions needed to consider the weight stable.

A high number of divisions allows the transmitter to quickly detect stability of the weight, which is needed when executing tare and print commands.

<i>Value</i>	<i>Variation</i>
<i>0</i>	<i>Weight always stable</i>
<i>1</i>	<i>Stability determined quickly</i>
<i>2</i>	<i>Stability determined with medium parameters</i>
<i>3</i>	<i>Stability determined accurately</i>
<i>4</i>	<i>Stability determined with the highest accuracy</i>
<i>Default: 2</i>	

## AUTOZERO

### AUTOZERO WHEN SWITCHING ON [1304-1305]

This parameter defines the value of maximum weight that can be reset when the instrument is switched on.

This operation corresponds to zero calibration of the system and is executed only if the weight is stable and below the set value.

*Value: from 0 to Capacity.*  
*Default: 0*

## ZERO TRACKING

### **ZERO TRACKING [1306]**

This function allows you to perform temporary zero calibration compensating for the temperature drift of the weight.

Switching off the transmitter automatically restores the previous zero calibration.

The maximum weight that can be reset by this parameter is 2% of the capacity of the system.

To disable this function, set the value 0.

<i>Value</i>	<i>Variation</i>
<i>NONE</i>	<i>Control excluded</i>
<i>1</i>	<i>0.5 div/sec</i>
<i>2</i>	<i>1 div/sec</i>
<i>3</i>	<i>2 div/sec</i>
<i>4</i>	<i>3 div/sec</i>

*Default: NONE*

## ZERO BAND

### **ZERO BAND [1307]**

This parameter defines the number of divisions that can be reset by pressing the zero button on the front or the associated Input.

*Values: from 0 to 200.*

*Default: 100*

## CELL CAPACITY

### **PERCENTAGE OF THE LOAD CELLS CAPACITY [1307]**

*This parameter modifies the percentage of the load cell capacity, calculated from the total flow divided by the number of cells present. Eg 4 cells total capacity 8000 kg, F.S. single cell 2000kg. Setting the value to 50, the overload report of the single cell will occur when the weight exceeds 1000 kg.*

*Values from 0 to 200.*

*Default: 100*

## FILTER - SETTING FILTER PARAMETERS

### GIG. BAND

#### WEIGHT FILTER VALUE [1201]

This parameter adjusts not only the refresh rate of the display, but specially the serial and analogue output. The maximum refresh rate of the display is limited to 25 Hz

High filter values speed up the weight update.

Low values of the filter slow down the weight update.

Factor (Hz)	Settling Time (mS)	ADC Freq (Hz)	N readings	Monotony Time (mS)	Oscillation time (mS)	Oscillation range (div)
MANUAL [0]		Selectable	Settable	Settable	Settable	Settable
25 [1]	40	250	11	200	4000	16
10 [2]	100	100	9	200	3000	16
5 [3]	200	50	9	200	2500	16
2 [4]	500	25	13	200	2000	16
1,25 [5]	800	10	8	250	1500	25
1 [6]	1000	10	11	300	1500	25
0,8 [7]	1250	5	7	400	1500	25
0,5 [8]	2000	5	11	500	1200	30
0,25 [9]	4000	5	19	600	1000	30

*Default: 1,25 Hz*

**The following parameters are visible and therefore can be set, only if the parameter selection is MANUAL.**

### CONV. RATE

#### ADC SPEED [1202]

With this parameter, the frequency of weight acquisition is adjusted. If the parameter changes to values higher than 12.5 Hz, the weight must be stable. In case of instability the instrument will immediately indicate an error message.

Selectable Values:

5 [0]

10 [1]

25 [2]

50 [3]

100 [4]

250 [5]

## AVERAGE

### **NUMBER OF READINGS ON AVERAGE [1203]**

With this parameter you set the number of readings that the filter will use to establish the average weight value.

*Values: from 0 to 50.*

## NONOTONY

### **MONOTONY TIME [1204]**

Parameter used to stabilize the weight when continuous variation of the last digit is detected. Normally used in case of resolution of the weight exceeding 10,000 divisions or with low sensitivity of the input signal. Value expressed in mS.

*Values: from 0 to 999.*

## TIME OSCILL.

### **OSCILLATIONS TIME [1205]**

Parameter used in conjunction with oscillation Range to reduce the lens weight changes and repetitive typical in lifting systems. Enter the value of the oscillation time expressed in mS.

*Values: from 0 to 999.*

## RANGE OSCILL.

### **OSCILLATIONS RANGE [1206]**

As for the parameter Oscillation time, used to reduce the oscillations. Enter the value of the oscillation expressed in weight divisions.

*Values: from 0 to 99.*

## SETTING FUNCTIONAL FEATURES

### STANDBY TIME

#### **STAND BY [1001]**

Idle time beyond which the instrument automatically assumes a low brightness status and keypad lock.

0 = deactivated function.

*Values: from 0 to 999.*

*Default: 0*

### KEY LOCK

#### **KEYPAD LOCK [1002]**

Set of 4 binary values that correspond to the 4 keys.

0 → key not locked

1 → key locked

(e.g. 0101 corresponds to locking the 2nd and 4th key).

*Values from 0000 to 1111.*

*Default: 0000*

### PIN . CODE

#### **PASSWORD SETTING [1003]**

If programmed, to access the programming menu you must enter the password. In the event of subsequent accesses it is no longer necessary to type the password until the stand-by intervenes or the instrument is powered off.

*Values from 0 to 9999.*

*Default: 0000 (no Password)*

### LANGUAGE

#### **LANGUAGE SETTING**

It allows operator to choose the user interface language.

*Value that can be selected:*

*ITALIANO [0]*

*INGLESE [1]*

*Default: ITALIANO*

### PEAK .

#### **PEAK FUNCTION [1004]**

Allows the peak function to be available or not and refers it to the net or gross weight.

If the application does not provide this feature you can disable it.

*Selectable setting:*

*NONE [0]*

*NET [1]*

*GROSS [2]*

*Default: NONE*

## IMBALANCE

### **UNBALANCING ALARM**

If programmed, it is the maximum weight difference between the value measured by the single load cell and the average value.

0 = function deactivated.

*Values from 0 to Capacity.*

*Default: 0*

### **DISPLAYED PARAMETERS ONLY IF OPTIONAL MEMORY INSTALLED**

DATALOG.

#### **DATALOGGER [1005]**

Allows you to save the weight and I/O status in the optional memory in Excel format. The logging can be a single measurement or a continuous series of measurements from the start of storage (max 1000 measurements). The memory can contain a maximum of 60000 records, after which the oldest records are overwritten.

*Selectable setting:*

*NONE [0]*

*SINGLE [1]*

*CONTIN. [2]*

*Default: NONE*

LOG. TRG.

#### **TRIGGER DATALOGGER [1006]**

If the datalogger is enabled, select whether storage is done manually (by button or input), or on activation of output 1 or 2. To start storing by key, press and hold the SET button. Storage can be interrupted at any time by pressing the ZERO key.

*Selectable setting:*

*MANUAL [0]*

*OUT1 [1]*

*OUT2 [2]*

*Default: MANUAL*

LOG. FRQ.

#### **DATALOGGER FREQUENCY [1007]**

If the datalogger is enabled, select the storage frequency of data (datalogger). The maximum frequency corresponds to that of weight acquisition (maximum frequency 250 Hz).

*Selectable setting:*

*10 MIN. [0], 5 MIN. [1], 1 MIN. [2]*

*10 SEC. [3], 5 SEC. [4], 2 SEC. [5]*

*1 HZ [6], 5 HZ [7], 10 HZ [8]*

*HIGH [9]*

*Default: 10 MIN.*



LOGDNL .

### **DOWNLOAD LOG**

Log download function, the records are transmitted through the USB key of the instrument. This function can be interrupted at any time by pressing the ZERO key.

At the end of the transmission you are prompted to delete the log, confirm by pressing PRG or cancel by pressing the ZERO weight key.

LOGERS .

### **LOG DELETION**

Log delete function, confirm with the PRG key or cancel with the ZERO key.

**NOTE:** In the download function of the log the records are transmitted in the followings format (starting from the oldest record):

<Tempo>; <Gross>; <Net>; <Peak>; <Inputs>; <Outputs> CR LF

Or in case of Date and Time option

<Date> ; <Time> ; <Lordo> ; <Netto> ; <Picco> ; <Ingressi> ; <Uscite> CR LF

Where:

**Tempo:** field consists of six ASCII characters with the value of the recording time justified to the right (value in seconds from 0 to 999999, without insignificant zeros) If the LOG function is configured to store a single record at a time, this field is always 0.

**Date:** field consists of eight ASCII characters with the value of the recording date, in the format "dd/mm/yy".

**Time:** field consists of eight ASCII characters with the value of the recording time, in the format "hh:mm:ss".

**Gross Net Peak:** fields consisting of 8 ASCII characters with the weight value justified to the right (without insignificant zeroes, with decimal points and negative signs).

**Inputs:** two ASCII characters, "0" (30h, input disabled) or "1" (31h, input enabled). Which indicate the status of input 1 and the status of input 2.

**Outputs:** two ASCII characters, "0" (30h, ouput disabled) or "1" (31h, output enabled). Which indicate the status of output 1 and the status of output 2.

## SET DATE AND TIME



This menu is shown only with clock hardware installed.

### DATE

#### SET DATE

Parameter for the adjustment of the current date

Format of selectable value: dd.mm.yy

*dd from 01 to 31*

*mm from 01 to 12*

*yy from 00 to 99*

*Default: actual date*

### TIME

#### SET TIME

Parameter for the adjustment of the current time

Format of selectable value: hh:mm

*hh from 00 to 23*

*mm from 00 to 59*

*Default: actual time*

## OPERATING FUNCTIONS - LOAD CELL SIMULATION

In the event of a load cell breaking, it is possible to set the instrument to simulate the faulty cell, interpolating the values of the adjacent load cells.

This procedure allows the operator to use the instrument even if a load cell breaks, waiting for it to be replaced.

## OPERATING FUNCTIONS - DISPLAY OF SINGLE LOAD CELLS

The instrument can show the mV / V signal of all load cells or the relative percentages and the total, so as to easily identify structural problems and unbalances.

Net ▼	1:	0.985
	2:	1.352
	3:	0.458
	4:	0.625
	<b>2.962 kg</b>	

▼	1:	25.0
	2:	24.3
	3:	26.7
	4:	24.0
	<b>100.0 %</b>	

▼	1:	0.2351
	2:	0.4320
	3:	0.3747
	4:	0.2987
	<b>0.3351 mV</b>	

▼	1:	0.2351	5:	0.3574
	2:	0.4320	6:	0.5519
	3:	0.3747	7:	0.2331
	4:	0.2987	8:	0.2548
	<b>0.3422 mV</b>			

## **LOAD CELL EMULATION**

As mentioned in the previous paragraph, when one of the load cells is damaged or disconnected, the following message appears on the display and the relay output contact 2 opens..

OL X

(Where x is the number of the faulty load cell)

By pressing the PRG key the faulty load cell is excluded from the weighing system which will continue to operate. The instrument automatically assigns to the excluded load cell a weight value based on the average of the weight values detected by the other still functioning cells. If the "OTHER DISPLAYS" function has been activated, while the individual weight values are displayed, the one automatically assigned to the excluded cell flashes on the display. Instead, in the display of the single signals coming from the load cells, the value in mV/V of the excluded cell is not displayed.

When the faulty cell is repaired or replaced, the instrument will automatically recognize it by including it again in the weighing system, without the need for further intervention by the operator..

# SERIAL COMMUNICATION PROTOCOLS

The continuous transmission is carried out at the refresh rate of the weight, consistent with the serial transmission baud rate. In case of communication on the ethernet port, the continuous transmission frequency is limited to 12.5 Hz.

## CONTINUOUS, AUTOMATIC AND ON DEMAND ASCII PROTOCOLS

In case of configuration of the serial port for the total weight alone, set DATA in the CONNECTIONS menu = TOTAL WEIGHT,

STX	<Total Weight status>	<Total Weight>	ETX	<chksum>	EOT
-----	-----------------------	----------------	-----	----------	-----

In case of configuration of the serial port to transmit the single weight, DATA parameter in the CONNECTIONS menu = SINGLE WEIGHTS. The length of the string varies according to the number of active channels.

STX	<status 1>	<weight 1>	<weight 2>	<...>	<weight 8>	ETX	<chksum>	EOT
-----	------------	------------	------------	-------	------------	-----	----------	-----

Where:

STX (start of text) = 0x02h

ETX (end of text) = 0x03h

EOT (end of transmission) = 0x04.

**<status>** = character encoded as per the following table (bit = 1 if condition TRUE):

Bit 7	Bit 6	Bit 5	Bit 4	Bit 3	Bit 2	Bit 1	Bit 0
0	0	1	1	Tare Entered	Zero band	Stable weight	Centre zero

**<weight>** = field consisting of 8 ASCII characters with the weight value justified to the right (without insignificant zeroes, with decimal points and negative signs).

The weight value transmitted may be the net weight, the gross weight or the peak value, depending on the transmitted data selected (parameter MODE) in the configuration menu of the serial communication ports (see related paragraph).

In conditions of overweight the field assumes the value: "^^^^^^^^".

In conditions of underweight greater than 999999, the field assumes the value: "\_\_\_\_\_".

In conditions of weight reading error the field assumes the value: " O-L ".

**<weighing ID>** = field consisting of seven ASCII characters with the identifier code of the weight justified to the right (without insignificant zeros).

**<chksum>** = checksum of the string data. It is calculated by performing the exclusive OR (XOR) of all the characters between STX (or from <Addr>) and ETX, with the exclusion of the latter two; the result of the XOR is broken up into 2 characters considering the upper 4 bits (first character) and the lower 4 bits (second character) separately; the 2 characters obtained are then ASCII encoded;

(example: XOR = 5Dh; <csum> = "5Dh" i.e. 35h and 44h).



*In the case of automatic and manual communication protocols, between 2 successive transmissions the weight must have a variation of at least 20 divisions.*

## **SLAVE TRANSMISSION PROTOCOL**

### **LIST OF THE CONTROLS AVAILABLE:**

1. Request for the net and gross weight and current peak.
2. Autotare command
3. Zero command
4. Peak reset command
5. Programming two weight setpoints
6. Requesting the programmed setpoints.
7. Logic output activation
8. Request Input status
9. Command of setpoints storage in permanent memory.
10. Change in net weight.
11. Change in gross weight.
12. DeleteTare command.
13. Request for Net weight.
14. Request for Gross weight.

The unit connected to the instrument (typically a personal computer) acts as a MASTER and is the only unit that can start a process of communication.

The process of communication must be made by the transmission of a string by the MASTER, followed by a reply from the SLAVE concerned.

### **CONTROLS FORMAT DESCRIPTION:**

The double quotes enclose constant characters (observe upper and lower case); the < and > symbols contain variable numeric fields. The <addr> is the instrument identification. In case of communication on the RS485 port, is obtained by adding 80h to the instrument's address value (for example with address 3 <addr> = 80h + 03h = 83h). In case of communication on the RS232 port, the <addr> must always be equal to 81h, or, in case of communication on the Ethernet port, the <addr> must always be equal to FFh

#### **1. REQUEST FOR THE NET AND GROSS WEIGHT AND CURRENT PEAK**

Master: <Addr> "N" EOT

DAT 400: "N" <Addr> <status> <net> <gross> <peak> ETX <checksum> EOT

#### **2 AUTO-TARE COMMAND**

Master: <Addr> "A" EOT

UWT 6008: <Addr> "A" ACK EOT or <Addr> NAK EOT

#### **3. SEMI-AUTOMATIC ZERO COMMAND**

Master: <Addr> "Z" EOT

UWT 6008: <Addr> "Z" ACK EOT or <Addr> NAK EOT

#### **4. PEAK VALUE RESET COMMAND**

Master: <Addr> "X" EOT

UWT 6008: <Addr> "X" ACK EOT or <Addr> NAK EOT

## 5. PROGRAMMING TWO WEIGHT SET-POINTS

Master: <Addr> "S" <s1> <s2> ETX <csum> EOT

UWT 6008: <Addr> "S" ACK EOT or <Addr> NAK EOT

## 6. REQUESTING PROGRAMMED SET-POINTS

Master: <Addr> "R" EOT

UWT 6008: <Addr> "R" <s1> <s2> ETX <csum> EOT or <Addr> NAK EOT

## 7. ACTIVATION OF LOGIC OUTPUTS.

Master: <Addr> "U" <outputs> EOT

UWT 6008: <Addr> "U" ACK EOT or <Addr> NAK EOT

## 8. STATUS REQUEST OF LOGIC INPUTS

Master: <Addr> "I" EOT

UWT 6008: <Addr> "I" <inputs> ETX <csum> EOT or <Addr> NAK EOT

## 9. COMMAND FOR STORING SET-POINTS IN THE PERMANENT MEMORY.

Master: <Addr> "E" EOT

UWT 6008: <Addr> "E" ACK EOT or <Addr> NAK EOT

*In the case of a communication error or a command that is not recognised, UWT 6008 responds with the following string:*

UWT 6008: <Addr> NAK EOT

**<s1> and <s2>:** formatted as weight field.

**<outputs> and <inputs>:** single ASCII character encoded as per the following table (bit = 1 if input/output enabled).

BIT 7	BIT 6	BIT 5	BIT 4	BIT 3	BIT 2	BIT 1	BIT 0
0	0	1	1	0	0	Input 2 / output 2	Input 1 / output 1

## 10. CHANGE FROM GROSS TO NET WEIGHT

Master: <Addr> "CN" EOT

UWT 6008: <Addr> "C" ACK EOT or <Addr> NAK EOT

## 11. CHANGE FROM NET TO GROSS WEIGHT

Master: <Addr> "CL" EOT

UWT 6008: <Addr> "C" ACK EOT or <Addr> NAK EOT

## 12. DELETE TARE COMMAND

MASTER: <Addr> "DT" EOT

UWT 6008: <Addr> "D" ACK EOT or <Addr> NAK EOT

## 13. REQUEST FOR NET WEIGHT (used for repeater program PDAT06)

MASTER: <Addr> "W" "N" EOT

UWT 6008: <Addr> "W" <rip status> <net> ETX <csum> EOT or <Addr> NAK EOT

## 14. REQUEST FOR GROSS WEIGHT (used for repeater program PDAT06)

MASTER: <Addr> "W" "G" EOT

UWT 6008: <Addr> "W" <rip status> <gross> ETX <csum> EOT or <Addr> NAK EOT

where:

**<rip status>**: character encoded as per the following table (bit = 1 in case of true condition).

Bit 7	Bit 6	Bit 5	Bit 4	Bit 3	Bit 2	Bit 1	Bit 0
0	0	1	1	0 = net 1 = gross	Zero band	Stable weight	Zero center

**<net> <gross>** = field consisting of 8 ASCII characters with the net and gross weight value justified to the right (without insignificant zeroes, with decimal points and negative signs).

In overweight conditions the field assumes the value: "^^^^^^^^".

In conditions of underweight (negative weight greather of 999999), the field assumes the value: "\_\_\_\_".

Under weight reading error conditions, the field assumes the value: " O-L ".

**<s1> <s2> <s3> <s4>** = Formatted as weight field (see <net> and <gross>). The setpoint 3 and 4 (fields <s3> and <s4>) must be managed only in case of hardware with 4 outputs. The setpoint values must be lower than the full scale parameter.

**<input>**: encoded character as per the following table (bit = 1 in the case of true condition)

Bit 7	Bit 6	Bit 5	Bit 4	Bit 3	Bit 2	Bit 1	Bit 0
0	0	1	1	0	0	Input 2	Input 1

**<output>**: encoded character as per the following table (bit = 1 in the case of true condition).

Bit 7	Bit 6	Bit 5	Bit 4	Bit 3	Bit 2	Bit 1	Bit 0
0	0	1	1	Output 4	Output 3	Output 2	Output 1



## PRINTER PROTOCOL

Data transmission protocol to Plus Printer

Printing can be started by pressing a key (see section FUNCTION OPERATIONAL) or by input (see paragraph SETTING I/O).

Here is an example of printer.

216/06/16	15:32
Net	209.0 kg
Gross	211.5 kg
Tare	2.5 kg
Peak	268.5 kg
Code	212456

21/06/18	16:38
Cella 1	17.1 ‰
Cella 2	10.5 ‰
Cella 3	11.8 ‰
Cella 4	8.5 ‰
Cella 5	21.9 ‰
Cella 6	11.9 ‰
Cella 7	9.6 ‰
Cella 8	8.7 ‰
Lordo	270.0 kg

- Date is printed only in case of hardware with time clock.
- The peak value is only printed if the peak function is enabled.

The conditions to printing are:

- Stable weight (or stabilized within 3 seconds from command).
- Since the last executed weigh, the weight has undergone a change of at least 20 divisions (delta weight).
- Gross weight less than the maximum capacity.

## MODBUS RTU PROTOCOL

The addresses set out in the tables follow the standard routing specified in the reference guide of Modicom PI-MBUS-300 an extract of which is provided below to help the user communicate with the instrument.

*“All data addresses in Modbus messages are referenced to zero. The first occurrence of a data item is addressed as item number zero. For example:*

*The coil known as ‘coil 1’ in a programmable controller is addressed as coil 0000 in the data address field of a Modbus message.*

*Coil 127 decimal is addressed as coil 007E hex (126 decimal).*

*Holding register 40001 is addressed as register 0000 in the data address field of the message. The function code field already specifies a ‘holding register’ operation. Therefore the ‘4XXXX’ reference is implicit.”*

To confirm a new value entered in E2prom, run the MAKE – BACKUP function. If this function is not performed, by switching off, the UWT 6008, the value before the change will be restored.

Unless otherwise specified, the numerical values (such as addresses, codes and data) are expressed as decimal values.

The MODBUS RTU protocol is available only on COM2 RS485.

## HANDLING OF COMMUNICATION ERRORS

The CRC (Cyclic Redundancy Check) is carried out to check the communication strings. In the case of a communication error, the slave does not respond with a string. The master must consider a timeout for receipt of the response. If it does not receive a response, a communication error has occurred

## HANDLING OF RECEIVED DATA ERRORS

In the case of a string that has been received correctly but cannot be executed, the slave responds with an EXCEPTIONRESPONSE as indicated in the table below.

CODE	DESCRIPTION
1	ILLEGAL FUNCTION (The function is not valid or not supported)
2	ILLEGAL DATA ADDRESS (The address of the specified data is not available)
3	ILLEGAL DATA VALUE (The values of the received data are invalid)

## FUNCTIONS SUPPORTED:

FUNCTION	DESCRIPTION
01	READ COIL STATUS (Reading the status of the logic outputs)
02	READ INPUT STATUS (Reading the status of the logic inputs)
03	READ HOLDING REGISTERS (Reading the programmable registers)
04	READ INPUT REGISTERS (Reading the “read only” registers”)
05	FORCE SINGLE COIL (Writing the status of each output)
06	PRESET SINGLE REGISTER (Writing a programmable register)
15	FORCE MULTIPLE COILS (Multiple writing of outputs)
16	PRESET MULTIPLE REGISTERS (Multiple writing of registers)
Funct + 80h	EXCEPTION RESPONSE

## LIST OF THE MODBUS PROTOCOL HOLDING REGISTERS

The instrument parameters that can be read or programmed via the communication interfaces available on the instrument, depending on the hardware configuration, are listed in the following table.

R type registers are readable while W type are writeable.

In case of Modbus TCP protocol, the address of the instrument (the "Unit Identifier" field) must always be FFh.

If a fieldbus is used (different from the Modbus), only the R or R/W registers will be in the input area and only the W or R/W registers will be in the output area.

The registers are 16 bit in size.

Address	Holding Register	R/W	Notes
0001	Status Register	R	See relevant table.
0002	Gross weight (MSW)	R	INT. value. - Most significant word
0003	Gross weight (LSW)	R	INT. value - Less significant word
0004	Net weight (MSW)	R	INT. value - Most significant word
0005	Net weight (LSW)	R	INT. value - Less significant word
0006	Peak (MSW)	R	INT. value - Most significant word
0007	Peak (LSW)	R	INT. value - Less significant word
0008	Digital Inputs	R	See relevant table.
0009	Digital Outputs	R	See relevant table.
0010	Unbalancing status	R	See relevant table.
0051	Weight 1 (MSW)	R	INT. value - Most significant word
0052	Weight 1 (LSW)	R	INT. value - Less significant word
...	...	...	...
0065	Weight 8 (MSW)	R	INT. value - Most significant word
0066	Weight 8 (LSW)	R	INT. value - Less significant word
0101	Weighing Net Weight (MSW)	R	INT. value - Most significant word
0102	Weighing Net Weight (LSW)	R	INT. value - Less significant word
0103	Weighted code (MSW)	R	INT. value - Most significant word
0104	Weighted code (LSW)	R	INT. value - Less significant word
0201	Set-Point 1 (MSW)	R/W	INT. value - Most significant word
0202	Set-Point 1 (LSW)	R/W	INT. value - Less significant word
0203	Set-Point 2 (MSW)	R/W	INT. value - Most significant word
0204	Set-Point 2 (LSW)	R/W	INT. value - Less significant word
0205	Set-Point 3 (optional, MSB)	R/W	INT. value - Most significant word
0206	Set-Point 3 (optional, LSB)	R/W	INT. value - Less significant word
0207	Set-Point 4 (optional, MSB)	R/W	INT. value - Most significant word
0208	Set-Point 4 (optional, LSB)	R/W	INT. value - Less significant word
0501	Data Register (MSW)	W	INT. value - Most significant word (See relevant table)
0502	Data Register (LSW)	W	INT. value - Least significant word (See relevant table)
0503	Command Register	W	See relevant table.
1001	Stand-by function	R/W	INT. value
1002	Keypad Lock function	R/W	See relevant table
1003	Password function	R/W	INT. value
1004	Peak function	R/W	See relevant table.
1005	Data-Logger function	R/W	See relevant table.
1006	Data-Logger Trigger	R/W	See relevant table.

1007	Data-Logger frequency	R/W	See relevant table.
1008	Language	R/W	See relevant table.
1009	Unbalancing Set (MSW)	R/W	INT. value - Most significant word
1010	Unbalancing Set (LSW)	R/W	INT. value - Less significant word
1101	Weight division value	R/W	See relevant table.
1102	Decimals	R/W	
1103	Capacity of load cells (MSW)	R/W	INT. value - Most significant word
1104	Capacity of load cells (LSW)	R/W	INT. value - Less significant word
1105	Sensitivity of load cells 1	R/W	INT. value
1106	Sensitivity of load cells 2	R/W	INT. value
1107	Sensitivity of load cells 3	R/W	INT. value
1108	Sensitivity of load cells 4	R/W	INT. value
1109	Sensitivity of load cells 5	R/W	INT. value
1110	Sensitivity of load cells 6	R/W	INT. value
1111	Sensitivity of load cells 7	R/W	INT. value
1112	Sensitivity of load cells 8	R/W	INT. value
1113	Fixed Tare (MSW)	R/W	INT. value - Most significant word
1114	Fixed Tare (LSW)	R/W	INT. value - Less significant word
1115	Gravity Calibration (MSW)	R/W	INT. value - Most significant word
1116	Gravity Calibration (LSW)	R/W	INT. value - Less significant word
1117	Gravity zone of use (MSW)	R/W	INT. value - Most significant word
1118	Gravity zone of use (LSW)	R/W	INT. value - Less significant word
1119	Measurement unit	R/W	INT. value
1120	Nr of Load cell used	R/W	INT. value
1151	Cal. table Zero signal (MSW)	R/W	INT. value - Most significant word
1152	Cal. table Zero signal (LSW)	R/W	INT. value - Less significant word
1153	Cal. table P1 signal (MSW)	R/W	INT. value - Most significant word
1154	Cal. table P1 signal (LSW)	R/W	INT. value - Less significant word
1155	Cal. table P2 signal (MSW)	R/W	INT. value - Most significant word
1156	Cal. table P2 signal (LSW)	R/W	INT. value - Less significant word
1157	Cal. table P3 signal (MSW)	R/W	INT. value - Most significant word
1158	Cal. table P3 signal (LSW)	R/W	INT. value - Less significant word
1159	Cal. table P4 signal (MSW)	R/W	INT. value - Most significant word
1160	Cal. table P4 signal (LSW)	R/W	INT. value - Less significant word
1161	Cal. table P5 signal (MSW)	R/W	INT. value - Most significant word
1162	Cal. table P5 signal (LSW)	R/W	INT. value - Less significant word
1163	Cal. table P1 value (MSW)	R/W	INT. value - Most significant word
1164	Cal. table P1 value (LSW)	R/W	INT. value - Less significant word
1165	Cal. table P2 value (MSW)	R/W	INT. value - Most significant word
1166	Cal. table P2 value (LSW)	R/W	INT. value - Less significant word
1167	Cal. table P3 value (MSW)	R/W	INT. value - Most significant word
1168	Cal. table P3 value (LSW)	R/W	INT. value - Less significant word
1169	Cal. table P4 value (MSW)	R/W	INT. value - Most significant word
1170	Cal. table P4 value (LSW)	R/W	INT. value - Less significant word
1171	Cal. table P5 value (MSW)	R/W	INT. value - Most significant word
1172	Cal. table P5 value (LSW)	R/W	INT. value - Less significant word

1201	Filter factor	R/W	See relevant table.
1202	Output rate ADC	R/W	See relevant table.
1203	Number of readings on average	R/W	INT. value
1204	Monotony Time	R/W	INT. value
1205	Oscillations Time	R/W	INT. value
1206	Oscillations Range	R/W	INT. value
1251	LC 1 balancing factor	R/W	INT. value
1252	LC 2 balancing factor	R/W	INT. value
1253	LC 3 balancing factor	R/W	INT. value
1254	LC 4 balancing factor	R/W	INT. value
1255	LC 5 balancing factor	R/W	INT. value
1256	LC 6 balancing factor	R/W	INT. value
1257	LC 7 balancing factor	R/W	INT. value
1258	LC 8 balancing factor	R/W	INT. value
1301	Full Scale (MSW)	R/W	INT. value - Most significant word
1302	Full Scale (LSW)	R/W	INT. value - Less significant word
1303	Weight stability	R/W	See relevant table
1304	Auto zero when switching on (MSW)	R/W	INT. value - Most significant word
1305	Auto zero when switching on (LSW)	R/W	INT. value - Less significant word
1306	Zero tracking	R/W	See relevant table.
1307	Resettable Divisions (MSW)	R/W	INT. value - Most significant word
1308	Resettable Divisions (LSW)	R/W	INT. value - Less significant word
1309	Percentage LC capacity	R/W	INT. value
1401	Input 1 function	R/W	See relevant table.
1402	Input 2 function	R/W	See relevant table.
1403	Output mode 1 – Function	R/W	See relevant table.
1404	Output mode 1 – Logic	R/W	See relevant table.
1405	Output mode 1 – Polarity	R/W	See relevant table.
1406	Output mode 1 – Stability	R/W	See relevant table.
1407	Hysteresis output 1	R/W	INT. value
1408	Timing output 1	R/W	INT. value
1409	Delay output 1	R/W	INT. value
1410	Output mode 2 – F unction	R/W	See relevant table.
1411	Output mode 2 – Logic	R/W	See relevant table.
1412	Output mode 2 – Polarity	R/W	See relevant table.
1413	Output mode 2 – Stability	R/W	See relevant table.
1414	Hysteresis output 2	R/W	INT. value
1415	Timing output 2	R/W	INT. value
1416	Delay output 2	R/W	INT. value
1417	Output mode 3 – Function	R/W	See relevant table.
1418	Output mode 3 – Logic	R/W	See relevant table.
1419	Output mode 3 – Polarity	R/W	See relevant table.
1420	Output mode 3 – Stability	R/W	See relevant table.
1421	Hysteresis output 3	R/W	INT. value
1422	Timing output 3	R/W	INT. value
1423	Delay output 3	R/W	INT. value
1424	Output mode 4 – Function	R/W	See relevant table.

1425	Output mode 4 – Logic	R/W	See relevant table.
1426	Output mode 4 – Polarity	R/W	See relevant table.
1427	Output mode 4 – Stability	R/W	See relevant table.
1428	Hysteresis output 4	R/W	INT. value
1429	Timing output 4	R/W	INT. value
1430	Delay output 4	R/W	INT. value
1501	Analogue Tare (MSB	R/W	INT. value - Most significant word
1502	Analogue Tare (LSW)	R/W	INT. value - Less significant word
1503	Analogue Full Scale (MSB	R/W	INT. value - Most significant word
1504	Analogue Full Scale (LSW)	R/W	INT. value - Less significant word
1505	Analogue Output Mode	R/W	See relevant table.
1506	Analogue Output Range	R/W	See relevant table.
1507	Regulation of analogue zero	R/W	INT. value Analogue output zero points, to end the regulation procedure it is necessary to send the data storage command to the permanent memory in the Command Register.
1508	Regulation of analogue full scale	R/W	INT. value Analogue output full scale points, to end the regulation procedure it is necessary to send the data storage command to the permanent memory in the command register.
2000	Monitor register	W	The programmed value is automatically copied in the Monitor Register R (2100).
2100	Monitor register	R	

**TABLE A - REGISTER STATUS CODING**

BIT	15	14	13	12	11	10	9	8
Description	Weight difference	Output 4	Output 3	Output 2	Output 1	Input 2	Input 1	Run Backup
BIT	7	6	5	4	3	2	1	0
Description	Not calibrated	Weight error	Over-load	Under-load	Tare entered	Zero band	Stable weight	Zero centre

**TABLE B - KEYPAD LOCK CODING**

BIT	15÷4	3	2	1	0
Description	Not used	SET Key	FUN Key	0 Key	PRG Key

*ATTENTION: the bits from 15 to 4 are not managed and are always equal to 0.*

**TABLE C - INPUTS/OUTPUTS CODING**

BIT	15÷2	3	2	1	0
Description	Not used	OUT 4 Active	OUT 3 Active	IN/OUT 2 Active	IN/OUT 1 Active

*ATTENTION: the bits from 15 to 4 are not managed and are always equal to 0.*

**TABLE D - DECIMALS AND DIVISION VALUE CODING**

ADDRESS	DESCRIPTION	ACCEPTED VALUES
1104	Division value	1 - 2 - 5 - 10 - 20 - 50
1105	Number of decimals	0 - 1 - 2 - 3 - 4

**TABLE E - BALANCING STATUS CODING**

VALUE	DESCRIPTION
0	Starting state, sample weight correctly acquired
1	Load Cell 1 balancing performed correctly
...	Load Cell n balancing performed correctly
8	Load Cell 8 balancing performed correctly

**TABLE E - DATA REGISTER / COMMAND REGISTER CODING**

REGISTER VALUE	COMMAND REGISTER FUNCTION	FUNCTION DATA REGISTER
0x0001	Semiautomatic zero	
0x0002	Auto-tare	
0x0003	Peak Reset	
0x0004	Zero calibration (**)	
0x0005	Full scale calibration (**)	Sample weight value in MSW and LSW
0x0006	Analogue Test	Value between 0 and 100 at intervals of 10 in LSW
0x0007	Saving the data in the permanent memory	
0x000A	Run command.	
0x000B	Change from gross to net	
0x000C	Change from net to gross	
0x000D	Acquisition of the zero signal (calibration table)	
0x000E	Set sample weight for balancing	Sample weight value in MSW e LSW
0x000F	Load Cell balancing (repeat n times, based on the number of load cells used)	
0x3FFF	Enabling Output Data Area (*)	

(\*) The instrument parameters managed in the Fieldbus Output Data Area are not changed until this command is sent. When the instrument is switched on the Output Data area is completely reset, the master fieldbus must read the parameter values from the Input Data Area and copy them in the relevant registers of the Output Data Area, then it must send the enable command in the Command Register. Otherwise all parameters managed in the Output Data area would be reset when switched on.

(\*\*) Function only available in FREE mode or if in METRIC mode with a calibration jumper enabled.

(\*\*\*) The instrument is undergoing configuration (TRUE flag during access to the SETUP menu of the instrument or during connection with PC "Optimization" software).

## EXAMPLES

### ZERO CALIBRATION

In condition of stable and unloaded scale write hexadecimal value 0004 in Command Register (0503). To permanently store in the memory the new Zero value, write hexadecimal value 0007 in Command Register (0503).

### FULL SCALE CALIBRATION

Put a sample weight on the scale, i.e 1256 kg.

Write in Data Register (0501 and 0502) the hex value of the sample weight: 04E8.

Write to the Command Register (0503), the hexadecimal value 0005.

You can write at the same time the Command Register and Data Register using the multiple registers function.

To permanently store in the memory the new value, write hexadecimal value 0007 in Command Register (0503).

### **USE OF SERIAL APPLICATIONS VIA THE USB PORT**

PC software "OPTIMATION" allows:

- total configuration of all the setup parameters;
- testing of the different hardware sections;
- consultation of the instrument documentation
- updating of instrument firmware
- storage over time of the weight values acquired by the instrument using the Datalogger function;
- saving and loading of the configuration parameters of the instrument on file.



# FIELDBUS PROTOCOL

The following table lists the registers of the input area (produced from the instrument and read by the master), common to all PROFIBUS, PROFINET, ETHERCAT, ETHERNET/IP fieldbuses.

The registers are 16 bit in size. The input area is updated at a fixed frequency of 150 Hz (80 Hz in case of PROFIBUS).

The size of the output area configured in the master fieldbus must match the size configured in the instrument.

## INPUT DATA AREA

Byte	Register address	INPUT AREA REGISTER	Notes
1-2	0	Status Register	See relevant table.
3-4	1	Gross weight (MSW)	INT. value - Most significant word
5-6	2	Gross weight (LSW)	INT. value - Less significant word
7-8	3	Net weight (MSW)	INT. value - Most significant word
9-10	4	Net weight (LSW)	INT. value - Less significant word
11-12	5	Peak (MSW)	INT. value - Most significant word
13-14	6	Peak (LSW)	INT. value - Less significant word
15-16	7	Weight of LC 1 (MSW)	INT. value - Most significant word
17-18	8	Weight of LC 1 (LSW)	INT. value - Less significant word
19-20	9	Weight of LC 2 (MSW)	INT. value - Most significant word
21-22	10	Weight of LC 2 (LSW)	INT. value - Less significant word
23-24	11	Weight of LC 3 (MSW)	INT. value - Most significant word
25-26	12	Weight of LC 3 (LSW)	INT. value - Less significant word
27-28	13	Weight of LC 4 (MSW)	INT. value - Most significant word
29-30	14	Weight of LC 4 (LSW)	INT. value - Less significant word
31-32	15	Weight of LC 5 (MSW)	INT. value - Most significant word
33-34	16	Weight of LC 5 (LSW)	INT. value - Less significant word
35-36	17	Weight of LC 6 (MSW)	INT. value - Most significant word
37-38	18	Weight of LC 6 (LSW)	INT. value - Less significant word
39-40	19	Weight of LC 7 (MSW)	INT. value - Most significant word
41-42	20	Weight of LC 7 (LSW)	INT. value - Less significant word
43-44	21	Weight of LC 8 (MSW)	INT. value - Most significant word
45-46	22	Weight of LC 8 (LSW)	INT. value - Less significant word
47-48	23	Digital Inputs	See relevant table.
49-50	24	Digital Outputs	
51-52	25	Monitor register	This value corresponds to the same register in the output area.
53-54	26	Net weight weighing (MSW)	INT. value - Most significant word
55-56	27	Net weight weighing (LSW)	INT. value - Less significant word
57-58	28	Code weighing (MSW)	INT. value - Most significant word
59-60	29	Code weighing (LSW)	INT. value - Less significant word
61-62	30	Set-Point 1 (MSW)	INT. value - Most significant word
63-64	31	Set-Point 1 (LSW)	INT. value - Less significant word
65-66	32	Set-Point 2 (MSW)	INT. value - Most significant word
67-68	33	Set-Point 2 (LSW)	INT. value - Less significant word
69-70	34	Set-Point 3 optional (MSW)	INT. value - Most significant word

71-72	35	Set-Point 3 optional (LSW)	INT. value - Less significant word
73-74	36	Set-Point 4 optional (MSW)	INT. value - Most significant word
75-76	37	Set-Point 4 optional (LSW)	INT. value - Less significant word
77-78	38	Capacity of load cells (MSW)	INT. value - Most significant word
79-80	39	Capacity of load cells (LSW)	INT. value - Less significant word
81-82	40	Sensitivity of load cells 1	INT. value
83-84	41	Sensitivity of load cells 2	INT. value
85-86	42	Sensitivity of load cells 3	INT. value
87-88	43	Sensitivity of load cells 4	INT. value
89-90	44	Sensitivity of load cells 5	INT. value
91-92	45	Sensitivity of load cells 6	INT. value
93-94	46	Sensitivity of load cells 7	INT. value
95-96	47	Sensitivity of load cells 8	INT. value
97-98	48	Weight division value	See relevant table.
99-100	49	Decimals	See relevant table.
101-102	50	Fixed Tare (MSW)	INT. value - Most significant word
103-104	51	Fixed Tare (LSW)	INT. value - Less significant word
105-106	52	Stand-by function	INT. value
107-108	53	Keypad Lock function	See relevant table.
109-110	54	Password function	INT. value
111-112	55	Peak function	See relevant table
113-114	56	Data-Logger function	See relevant table
115-116	57	Data-Logger Trigger	See relevant table
117-118	58	Data-Logger frequency	See relevant table
119-120	59	Language	See relevant table
121-122	60	Filter factor	See relevant table

### READING EXAMPLE

To read the gross weight on the UWT 6008 it is needed to read the addresses from 3 to 6 of the Input Area.

To read the net weight is needed to read the addresses from 7 to 10 of the Input Area.

When the display shows the gross weight value of 12351 in the corresponding bytes there will be:

	Byte 3	Byte 4	Byte 5	Byte 6
Hex	00	00	30	3F

The following table lists the registers of the output area (written by the master and acquired by the instrument), common to all PROFIBUS, PROFINET, ETHERCAT, ETHERNET / IP Fieldbuses.

The registers are 16 bit in size. The registers written by the master in the output area, are read by the instrument at a fixed frequency of 150 Hz. (80 Hz in case of PROFIBUS)

The size of the output area configured in the master fieldbus must match the size configured in the instrument.

## OUTPUT DATA AREA

Byte	Register address	OUTPUT AREA REGISTER	Note
1-2	0	Command Register	See relevant table.
3-4	1	Data Register (MSW)	INT. value - Most significant word (See Table)
5-6	2	Data Register (LSW)	INT. value - Least significant word (See Table)
7-8	3	Monitor register	This value corresponds to the same register in the input area.
9-10	4	Set-Point 1 (MSW)	INT. value - Most significant word
11-12	5	Set-Point 1 (LSW)	INT. value - Less significant word
13-14	6	Set-Point 2 (MSW)	INT. value - Most significant word
15-16	7	Set-Point 2 (LSW)	INT. value - Less significant word
17-18	8	Set-Point 3 optional (MSW)	INT. value - Most significant word
19-20	9	Set-Point 3 optional (LSW)	INT. value - Less significant word
21-22	10	Set-Point 4 optional (MSW)	INT. value - Most significant word
23-24	11	Set-Point 4 optional (LSW)	INT. value - Less significant word
25-26	12	Capacity of load cells (MSW)	INT. value - Most significant word
27-28	13	Capacity of load cells (LSW)	INT. value - Less significant word
29-30	14	Sensitivity of load cells 1	INT. value
31-32	15	Sensitivity of load cells 2	INT. value
33-34	16	Sensitivity of load cells 3	INT. value
35-36	17	Sensitivity of load cells 4	INT. value
37-38	18	Sensitivity of load cells 5	INT. value
39-40	19	Sensitivity of load cells 6	INT. value
40-41	20	Sensitivity of load cells 7	INT. value
43-44	21	Sensitivity of load cells 8	INT. value
45-46	22	Weight division value	See relevant table.
47-48	23	Decimals	See relevant table.
49-50	24	Fixed Tare (MSW)	INT. value - Most significant word
51-52	25	Fixed Tare (LSW)	INT. value - Less significant word
53-54	26	Stand-by function	INT. value
55-56	27	Keypad Lock function	See relevant table.
57-58	28	Password function	INT. value
59-60	29	Peak function	See relevant table
61-62	30	Data-Logger function	See relevant table
63-64	31	Data-Logger Trigger	See relevant table
65-66	32	Data-Logger function	See relevant table
67-68	33	Language	See relevant table
69-70	34	Filter factor	See relevant table
71-72	35	Output rate ADC	See relevant table
73-74	36	Number of readings on average	INT. value
75-76	37	Monotony Time	INT. value

77-78	38	Oscillations Time	INT. value
79-80	39	Oscillations Range	INT. value
81-82	40	Full Scale (MSW)	INT. value - Most significant word
83-84	41	Full Scale (LSW)	INT. value - Less significant word
85-86	42	Weight stability	See relevant table
87-88	43	Auto zero when switching on (MSW)	INT. value - Most significant word
89-90	44	Auto zero when switching on (LSW)	INT. value - Less significant word
91-92	45	Zero tracking	See relevant table
93-94	46	Resettable Divisions (key >0<)	INT. value
95-96	47	Input 1 function	See relevant table
97-98	48	Input 2 function	See relevant table
99-100	49	Input 1 mode —Function	See relevant table
101-102	50	Input 1 mode —Logic	See relevant table
103-104	51	Input 1 mode —Polarity	See relevant table
105-106	52	Input 1 mode —Stability	See relevant table
107-108	53	Hysteresis input 1	INT. value
109-110	54	Timing input 1	INT. value
111-112	55	Delay input 1	INT. value
113-114	56	Input 2 mode —Function	See relevant table
115-116	57	Input 2 mode —Logic	See relevant table
117-118	58	Input 2 mode —Polarity	See relevant table
119-120	59	Input 2 mode —Stability	See relevant table
121-122	60	Hysteresis input 2	INT. value
123-124	61	Timing input 2	INT. value
125-126	62	Delay input 2	INT. value

## WRITING EXAMPLES

To write the set-up parameters following the example:

In the bytes 1-2 (Command Register) write value Hex 3FFF. This value opens the writing area of the UWT 6008.

Example: to change the default values of the UWT 6008 like the Capacity of the load cells, the Sensitivity and Division value to 15000, 2.9965 and 2:

Capacity	Byte 17	Byte 18	Byte 19	Byte 20
Hex	00	00	3A	98
Dec	15000			

Sensitivity	Byte 21	Byte 22
Hex	75	0D
Dec	29965	

Division	Byte 23	Byte 24
Hex	00	0D
Dec	13	

Save the data by writing the value Hex 7 in Command Register.

N.B. The UWT 6008 does not accept writing of the same values already written.

To perform Zero and FS Calibration it is not needed to abilitate the internal Writing Area of the UWT 6008.

**Zero Calibration:**

With empty system put Hex 4 in Command Register (bytes 1-2). The new Zero value is stored.

**Full Scale Calibration:**

Put a known weight on the system and write its value in the Data Register (from byte 3 to 6). Put value Hex 5 in Command Register. The weight value will be displayed.

## TROUBLESHOOTING

PROBLEM	POSSIBLE CAUSE	SOLUTION
The display shows the O-L message	The weight cannot be detected because the cell is not available or has been connected incorrectly.	Check the connections of the cells.
The hyphen is shown in the top display.	The acquired weight cannot be shown because it exceeds the available five digits or is greater than the capacity of the cells.	Configure setup parameters that are compatible with system features
The number of decimal places is wrong.	Incorrect division value selected.	Select the correct division value in the main menu.
The Instrument remains switched off	Wrong supply voltage	Power up the instrument with the correct supply voltage
Weight display is frozen	The load cell is not functioning properly or has not been properly connected	Use a multimeter and measure 5Vdc between EXC+ and EXC- and a lower value between SENSE+ and SENSE- (greater are the distance between the instrument and the load cells and lower will be the SENSE voltage) and check the variation in millivolt between SGN+ and SGN- when loading or unloading the load cells
Inputs and / or outputs does not work properly	Wiring or Software Setup Errors	Use the I / O Test Function to verify the correct operation of inputs and outputs and verify the settings of the specific program
The serial communication does not work properly.	Installation has been completed properly. Selection of operation of the serial interface is incorrect.	Check the connections as described in the installation manual. Select the settings as appropriate.
The semi-automatic zero-setting function does not work.	The gross weight exceeds the action limit of semi-automatic zero-setting. The weight doesn't stabilise.	To re-establish the zero, calibrate the weight. Wait for the weight to stabilise or adjust the weight filter parameter.
The semi-automatic tare function does not work.	The gross weight is negative or exceeds the maximum capacity. The weight doesn't stabilise.	Check the gross weight. Wait for the weight to stabilise or adjust the weight filter parameter.

## **EU Declaration of conformity (DoC)**

We

Pavone Sistemi s.r.l.  
Via Tiberio Bianchi, 11/13/15  
20863 Concorezzo, MB

**declare that the DoC issued under our sole responsibility and belongs to the following product:**

Apparatus model/Product: **UWT 6008**  
Type: Weighing instrument

The object of the declaration described above used as indicated in the installation manual and use, is in conformity with the relevant Union harmonisation legislation:

Directive **EMC 2014/30/EU** Electromagnetic Compatibility

The following harmonized standards and technical specification have been applied:

**EN 61000-6-2: 2005**  
**EN 61000-6-3: 2007 + A1 2011**  
**EN 61326-1: 2013**

Directive **LVD 2014/35/EU** Low Voltage Directive

The following harmonized standards and technical specification have been applied:

**EN 61010-1:2011**

Signed for end on behalf of:  
Concorezzo: 12/10/2018

Di Reda Donato - Manager



**PAVONE**SYSTEMS

**PAVONE SISTEMI S.R.L.**

Via Tiberio Bianchi, 11/13/15, 20863 Concorezzo (MB)

T 039 9162656 F 039 9162675 W [pavonesistemi.com](http://pavonesistemi.com)

Industrial Electronic Weighing Systems since 1963

